

# Service Manual

---

**Generator Set, Industrial  
And Marine Engines  
Electric Protective System**

---

 **WARNING**

## IMPORTANT SAFETY NOTICE

Proper repair is important to the safe and reliable operation of this product. This Service Manual outlines basic recommended procedures, some of which require special tools, devices or work methods. Although not necessarily all inclusive, a list of additional skills, precautions and knowledge required to safely perform repairs is provided in the SAFETY section of this Manual.

Improper repair procedures can be dangerous and could result in injury or death.

### **READ AND UNDERSTAND ALL SAFETY PRECAUTIONS AND WARNINGS BEFORE PERFORMING REPAIRS**

Basic safety precautions, skills and knowledge are listed in the SAFETY section of this Manual and in the descriptions of operations where hazards exist. Warning labels have also been put on to provide instructions and identify specific hazards which if not heeded could cause bodily injury or death to you or other persons. These labels identify hazards which may not be apparent to a trained mechanic. There are many potential hazards during repair for a untrained mechanic and there is no way to label the product against all such hazards. These warnings in the Service Manual and on the product are identified by this symbol:

 **WARNING**

Operations that may result only in mechanical damage are identified by labels on the product and in the Service Manual by the word **NOTICE**.

Caterpillar can not anticipate every possible circumstance that might involve a potential hazard. The warnings in this Manual are therefore not all inclusive. If a procedure, tool device or work method not specifically recommended by Caterpillar is used, you must satisfy yourself that it is safe for you and others. You should also ensure that the product will not be damaged or made unsafe by the procedures you choose.

### **IMPORTANT**

The information, specifications and illustrations in this book are on the basis of information available at the time it was written. The specifications, torque, pressures of operation, measurements, adjustments, illustrations and other items can change at any time. These changes can affect the service given to the product. Get the complete and most current information before you start any job. Caterpillar Dealers have the most current information available. For a list of the most current modules and form numbers available for each Service Manual, see the SERVICE MANUAL CONTENTS MICROFICHE REG1139F.

A83264 X2

**SYSTEMS OPERATION**

Component Description .....	4	Engine Shutdown: System Fault	
Component Location on Engine .....	5	Coolant Overheating .....	21
Individual Circuit Description .....	6-25	Engine Overspeed .....	23
Engine Runs: No System Fault		Loss of Engine Oil Pressure (at Speeds	
Below Oil Step Speed Setting (or Just		Above Oil Step Speed Setting) .....	15
Accelerating thru Step Speed) .....	17	Low Oil Pressure (at Speeds Below	
Rated Speed .....	13	Oil Step Speed Setting) .....	19
Starts to Run .....	11	Engine Stopped .....	7
2301 Electric Governor Control .....	25	Starting Engine .....	9
		Introduction .....	4

**SYSTEM PROBLEMS**

Preliminary Checks .....	30	Problem Identification Index .....	29
--------------------------	----	------------------------------------	----

**TROUBLESHOOTING**

Functional Test .....	26	Step Oil Pressure .....	36
Introduction to Troubleshooting Guide .....	29	System Arming .....	31
Speed Specification Chart .....	27	Troubleshooting Procedures	
System Troubleshooting Charts .....	30-37	A - Overspeed Setting Calibration .....	38
Crank Terminate .....	34	B - Crank Terminate Speed Adjustment .....	39
Overspeed .....	32	C - Oil Step Calibration .....	40
Preliminary Checks .....	30	D - Overspeed Verify Test .....	41
		E - Magnetic Pickup Verify .....	42
		F - ON/OFF Time Delay Relay .....	43

**WIRING DIAGRAMS**

Abbreviations		Engine Wiring Diagram .....	46
Component .....	44	Junction Box	
Wire Color Code .....	44	Identification .....	48
Customer Wiring .....	50, 51	Wiring Diagram .....	47
Electric Protective System Schematic .....	45	Wiring Harness .....	49

# ELECTRIC PROTECTIVE SYSTEM

## INTRODUCTION

The electric protective system is designed to activate an alarm or shut the engine off if there is a problem or a failure in any of four different engine systems. The engine systems monitored are: engine overspeed, starter motor crank terminate, engine oil pressure and engine coolant temperature.

The electric protective system consists of the basic components that follow: magnetic pickup, electronic speed switch, water temperature contactor switch, two time delay relays and two slave relays. This system monitors the engine from starting through rated speed.

## COMPONENT DESCRIPTION

**Magnetic Pickup (MPU)** - The magnetic pickup is a single pole, permanent magnet generator made of wire coils around a permanent magnet pole piece. As the teeth of the flywheel ring gear go through the magnetic lines of force around the pickup, an AC voltage is made. A positive voltage is made when each tooth goes by the pole piece. Each time the space between the teeth goes by the pole piece, a negative voltage is made. Engine speed is then determined by the frequency of these signals.

**Electronic Speed Switch (ESS)** - The 4W2218 Electronic Speed Switch can easily be identified by its black color (the earlier speed switch was yellow). This speed switch has controls (in a single unit) to monitor three of the basic functions. These three functions are:

**Engine Overspeed** - An adjustable engine speed setting (normally 118% of rated speed) that gives protection to the engine from damage if the engine runs too fast. This condition will cause a switch to close that shuts off both the inlet air and the fuel to the engine.

**Crank Terminate (Starter Motors)** - An adjustable engine speed setting that gives protection to the starter motor from damage by overspeed. This condition will cause a switch to open that stops current flow to starter motor circuit, and the starter motor pinion gear will then disengage from engine flywheel ring gear.

**Engine Step Oil Pressure** - An adjustable engine speed setting that gives protection to the engine from a failure caused by not enough oil pressure. To maintain desired protection through the complete speed

range of engine operation, two different oil pressure switches are used [280 kPa (40 psi), 140 kPa (20 psi)]. Once the step oil pressure speed setting is made, an engine that runs **above** this speed setting must maintain an oil pressure that is more than 280 kPa (40 psi). An engine that runs at a speed **below** this speed setting must maintain an oil pressure that is more than 140 kPa (20 psi). If either condition is not correct, a switch will close to activate an alarm or cause the fuel to be shut off to the engine.

**Water Temperature Contactor Switch** - This contactor switch is a separate unit (mounted in the regulator housing) that is wired into the shutdown circuit. It has an element that feels the temperature of the coolant (it must be in contact with the coolant). When the engine coolant temperature becomes too high, the switch closes to activate an alarm or cause the fuel to be shut off to the engine.

**Time Delay Relays** - These relays are special ON/OFF switches with two controls that will either make the relay activate immediately, or after a 9 second delay. One of the time delay relays is used to arm the shutdown system, and the other time delay relay controls the oil pressure circuits for the two oil pressure switches. Both time delay relays have a 70 second OFF delay to be sure of complete engine shutdown.

**Slave Relays** - These are standard type relays that, when energized, have contacts that open across one circuit and close across another circuit. When activated, one of the relays will activate an alarm or cause the fuel to be shut off, and the other relay will cause the inlet air to be shut off.

## COMPONENT LOCATIONS ON ENGINE

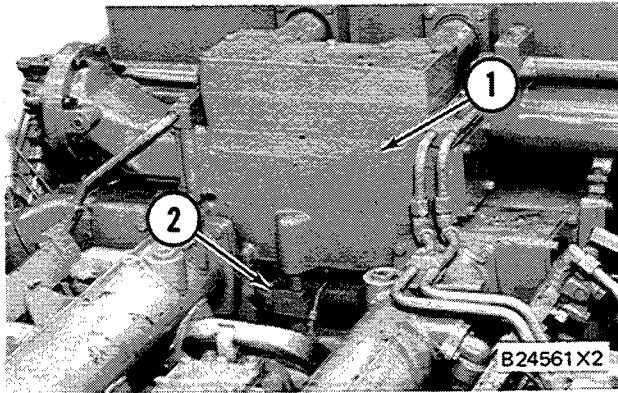

**WATER TEMPERATURE CONTACTOR SWITCH**  
 1. Regulator housing. 2. Contactor switch.

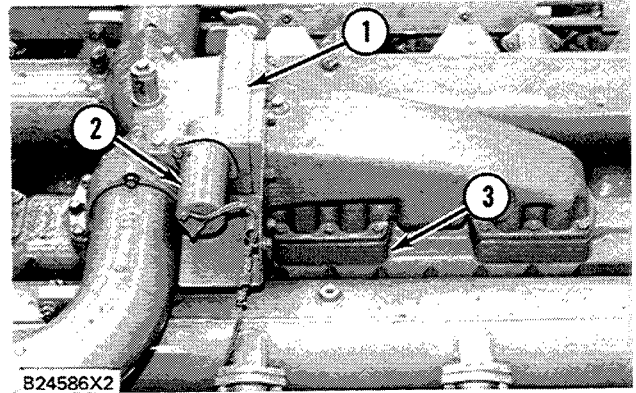

**AIR SHUTOFF SOLENOID**  
 1. Air shutoff housing. 2. Air shutoff solenoid. 3. After-cooler housing.

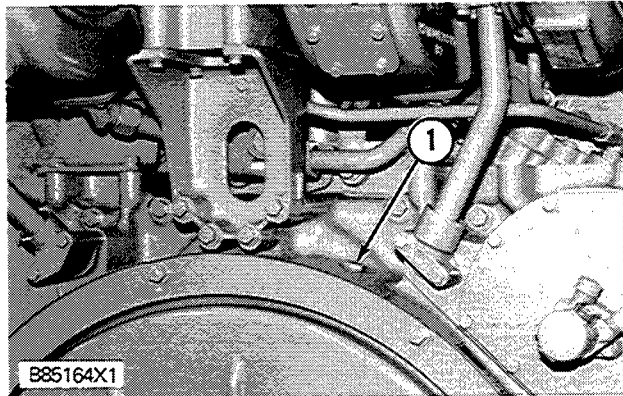

**LOCATION FOR MAGNETIC PICKUP  
 (Later Engines)**  
 1. Plug (one of three available locations on top of flywheel housing).

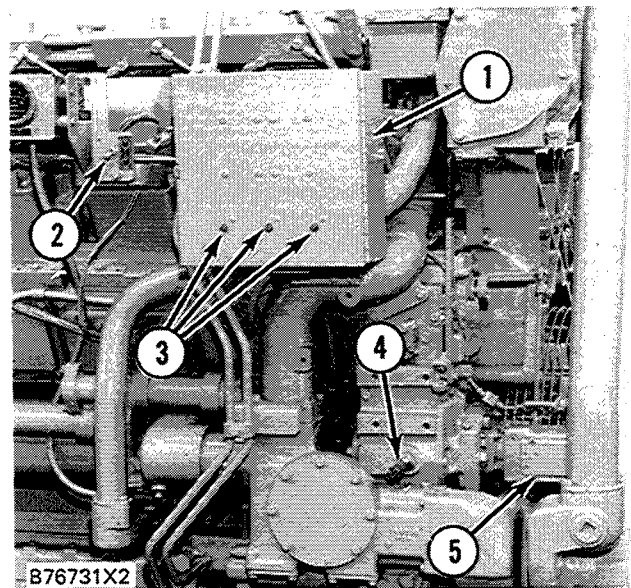

**JUNCTION BOX CLOSED**  
 1. Junction box. 2. Fuel shutoff switch. 3. Circuit breakers. 4. Magnetic pickup. 5. Electric governor actuator (EGA).

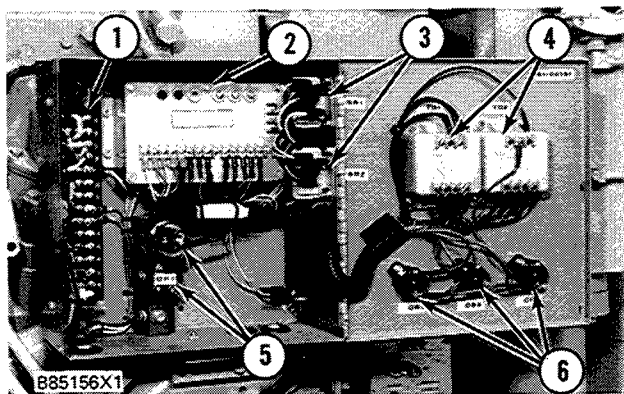

**JUNCTION BOX OPENED**  
 1. Terminal strips. 2. Electronic speed switch (ESS). 3. Slave relays. 4. Time delay relays. 5. Oil pressure switches. 6. Circuit breakers.

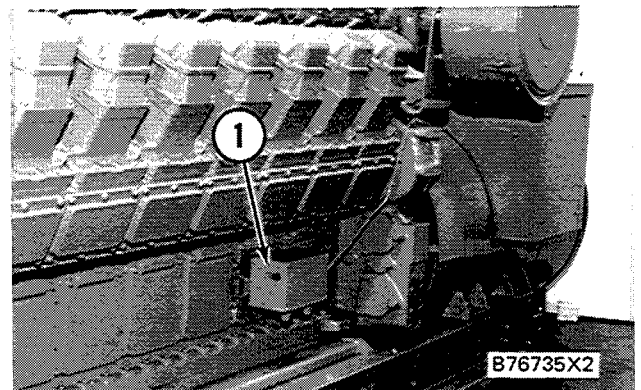

**LEFT SIDE OF ENGINE**  
 1. Enclosure group.

## INDIVIDUAL CIRCUIT DESCRIPTION

The information that follows show the current flow through the wiring schematic. As switches are opened or closed, either automatically or manually, the current flow of the individual circuit affected is shown schematically.

Also included (on each facing page) is a story that explains all the components involved for this particular condition, and why the current will take the path shown.

### **ENGINE STOPPED (Fig. 1)**

With the engine stopped, power is always available across terminals 3 and 4 of time delay relays (TD1 and TD2) and across terminals 5 and 6 of electronic speed switch (ESS). At this time all switches are in their normally open or normally closed positions.

ENGINE STOPPED

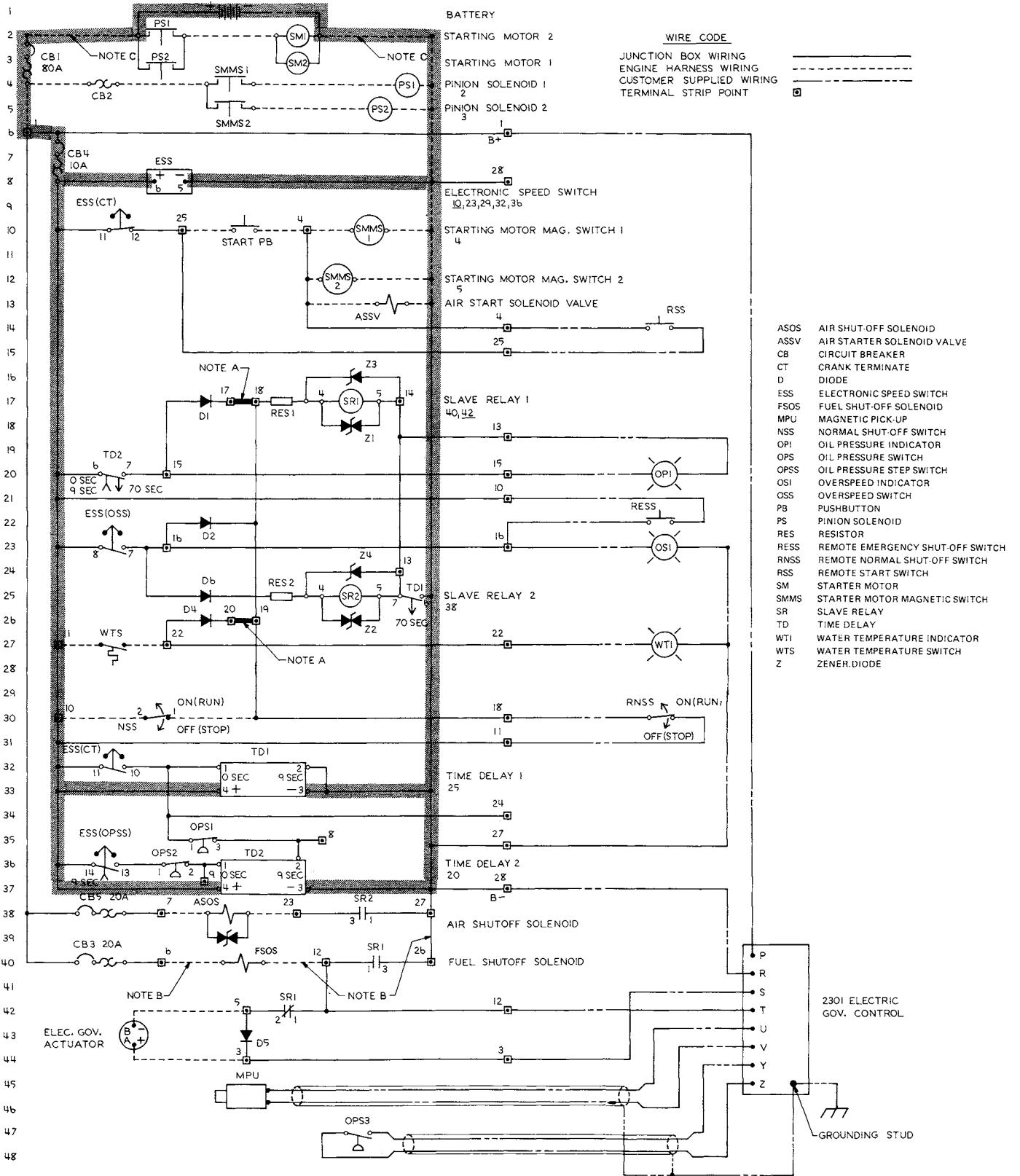

Fig. 1

## MANUAL START

### Electric Starter Motors (Fig. 2)

When the start pushbutton (PB) or remote start switch (RSS) is pushed, current will flow through starter motor magnetic switches (SMMS1 and SMMS2). With magnetic switches energized, contacts (SMMS1 and SMMS2) close and pinion solenoids (PS1 and PS2) are energized. This causes contacts (PS1 and PS2) to close, and starter motors (SM1 and SM2) will now crank the engine. When engine starts to run and the rpm increases to the speed of the crank terminate (CT) speed setting, the ESS(CT) switch will automatically open across terminals ESS-11 and ESS-12 to stop current flow to the start pushbutton.

### Air Starter Motor (Current Flow Not Shown in Fig. 2)

If engine has an air starter motor, current will flow through DC operated air start solenoid valve (ASSV) when start pushbutton (PB or RSS) is pushed. The ASSV will open the air supply to the air starter motor, which will now crank the engine. When the engine starts to run and the rpm increases to the speed of the crank terminate (CT) speed setting, ESS(CT) switch will automatically open across terminals ESS-11 and ESS-12 to stop current flow to ASSV pushbutton. This will move the valve to shut off the air supply to the air starter motor.



STARTING ENGINE WITH ELECTRIC STARTER MOTORS

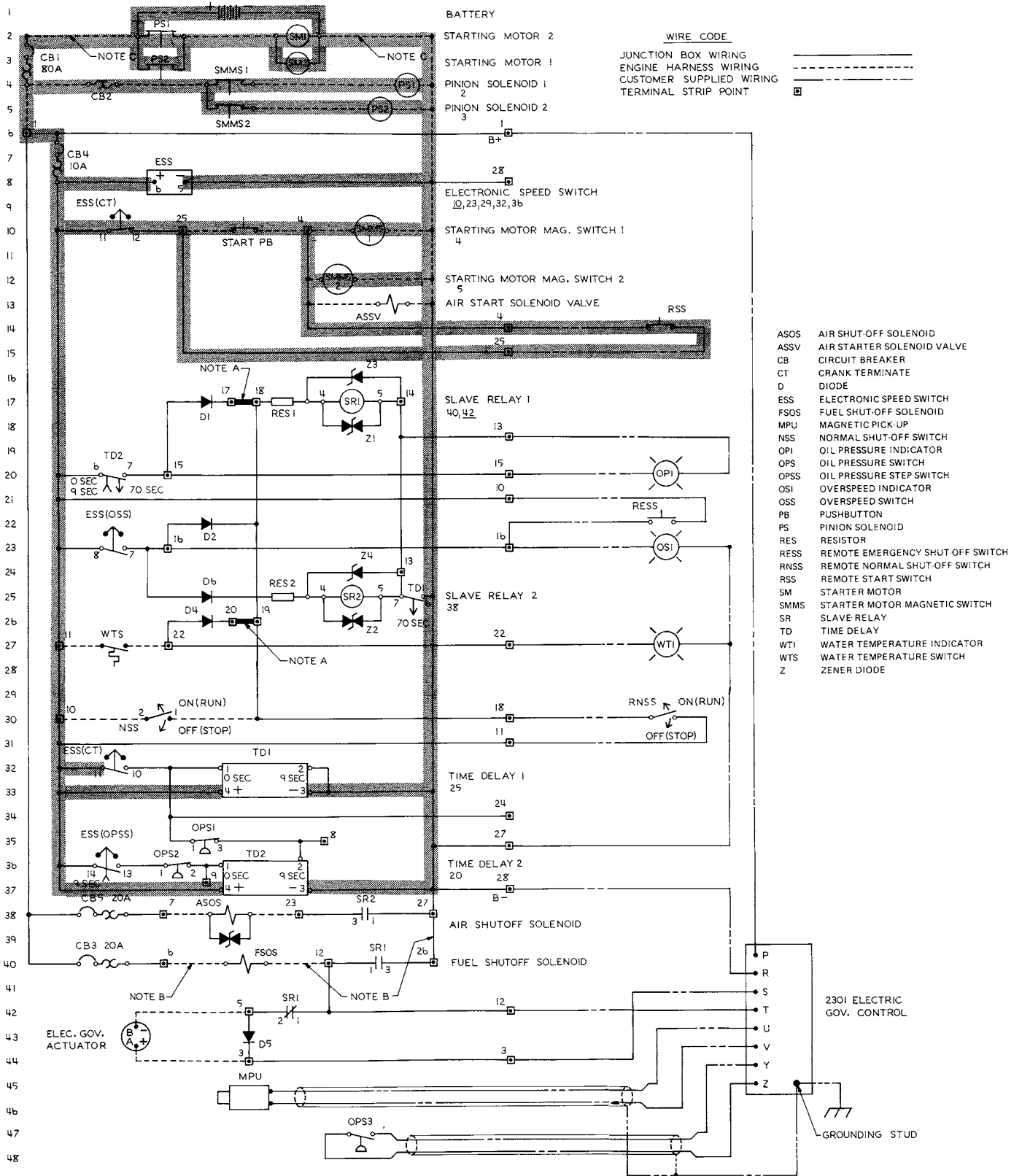

Fig. 2

### ENGINE STARTS TO RUN: NO FAULTS

When the engine starts to run, the speed will increase to the speed setting of the ESS crank terminate function, and the ESS(CT) switch across terminals ESS-11 and ESS-12 will open. The current flow is now stopped to the start pushbutton for the starter motor(s) as shown in Fig. 3.

When the ESS(CT) switch (line 10) **opens** across terminals ESS-11 and ESS-12, ESS(CT) switch (line 32) will **close** across terminals ESS-11 and ESS-10. This closed switch will give current flow to Control 1 (terminal 1) of time delay relay (TD1), and will immediately **close** switch (TD1) across terminals TD1-6 and TD1-7 (line 25). The complete protection system is now armed to activate an alarm or cause engine shutdown if there is a fault in any of the three engine systems now being monitored.

ENGINE STARTS TO RUN: NO FAULTS

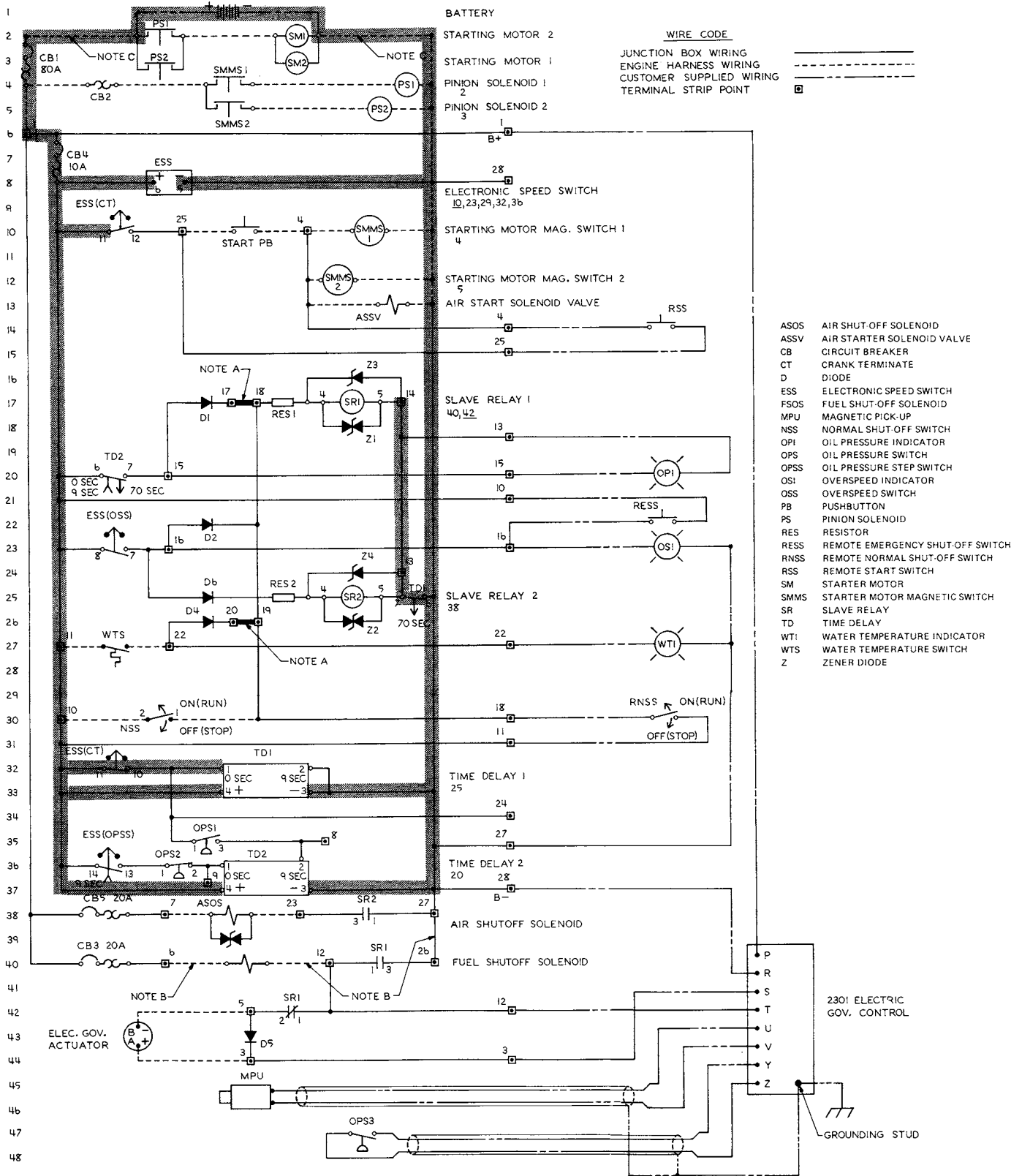

Fig. 3

**ENGINE RUNS AT RATED SPEED: NO FAULTS**

With no existing problems and engine running at rated speed, or at some speed above the oil step speed setting, the circuit will look like Fig. 4. The oil pressure step switch (OPSS) at line 36 is now **closed**, but oil pressure switch (OPS2) is now **open**, so there is still no current flow to TD2. The engine will continue to run with these conditions.

OPS2 will not open until there is at least 280 kPa (40 psi) oil pressure available, and after opening, will not close again until the oil pressure has dropped below 240 kPa (35 psi). The ESS(OPSS) switch is not activated to open until engine speed is the same as, or above, the step oil pressure speed setting. After it is activated, the ESS(OPSS) switch has a 9 second delay before it closes. This makes sure that oil pressure has time to increase enough to open OPS2, or system would constantly activate engine shutdown.

ENGINE RUNS AT RATED SPEED: NO FAULTS

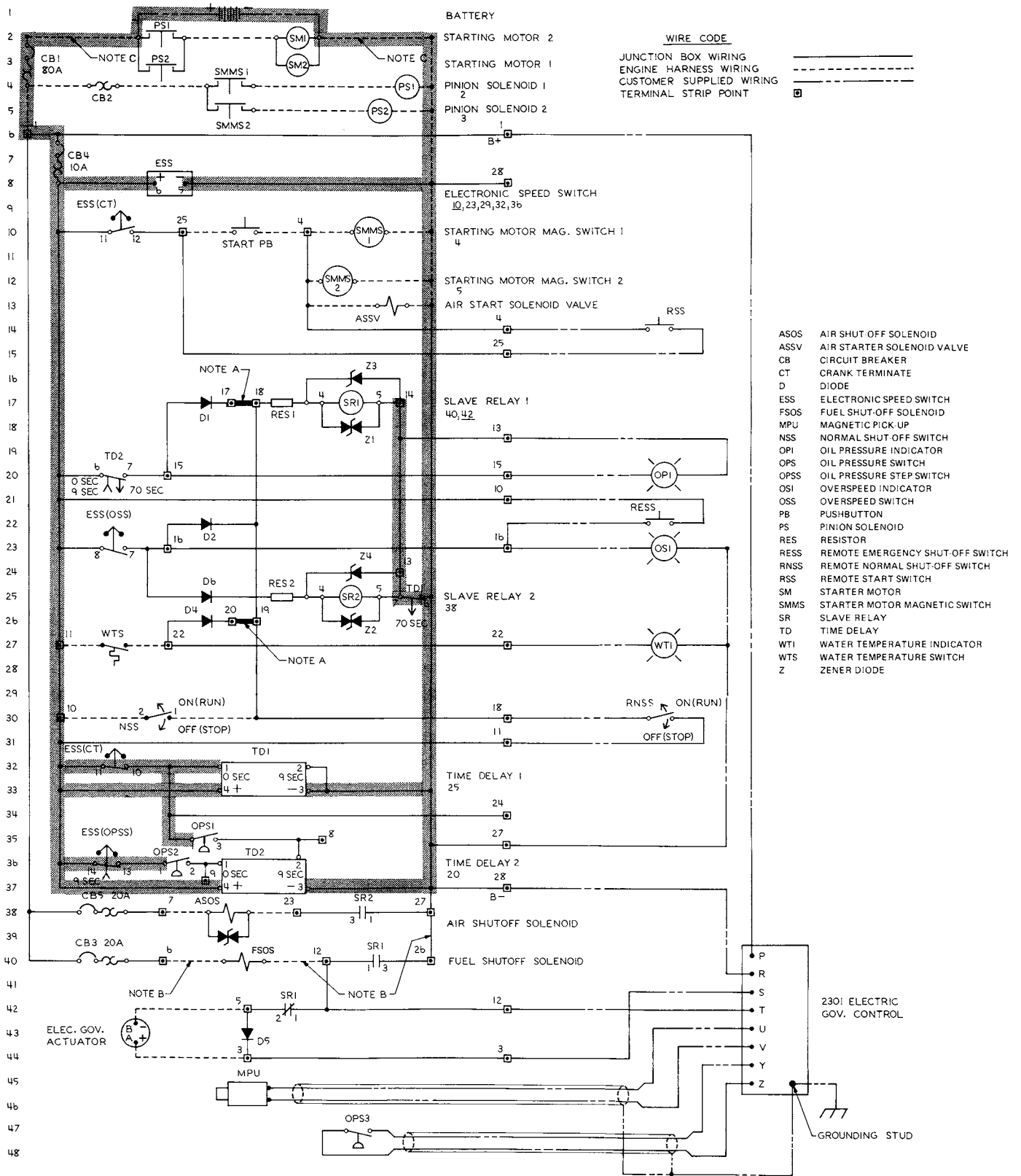

Fig. 4

**ENGINE SHUTDOWN DUE TO FAULT:  
LOSS OF ENGINE OIL PRESSURE  
(AT ENGINE SPEEDS ABOVE OIL STEP  
SPEED SETTING)**

The circuit of Fig. 5 shows the current flow if there is a fault in the high pressure side of the oil pressure circuit. When engine oil pressure drops below 240 kPa (35 psi), oil pressure switch (OPS2) will close. Since the engine is running at a speed above the step oil pressure setting, ESS(OPSS) switch is already closed and the circuit is now completed to Control 1 (terminal 1) of time delay relay (TD2). There is no time delay at Control 1, so TD2 relay contacts (line 20) will close immediately across terminals TD2-6 and TD2-7. This makes a complete circuit from the battery through TD1 contacts (line 25) to activate oil pressure indicator (OPI) and to energize slave relay (SR1).

When SR1 is energized, contacts across terminals SR1-1 and SR1-2 **open** and contacts across terminals SR1-1 and SR1-3 **close**. The circuit is now completed to energize fuel shut-off solenoid (FSOS), and the fuel is shut off to the engine.

**ENGINE SHUTDOWN DUE TO FAULT: LOSS OF ENGINE OIL PRESSURE  
(AT ENGINE SPEEDS ABOVE OIL STEP SPEED SETTING)**

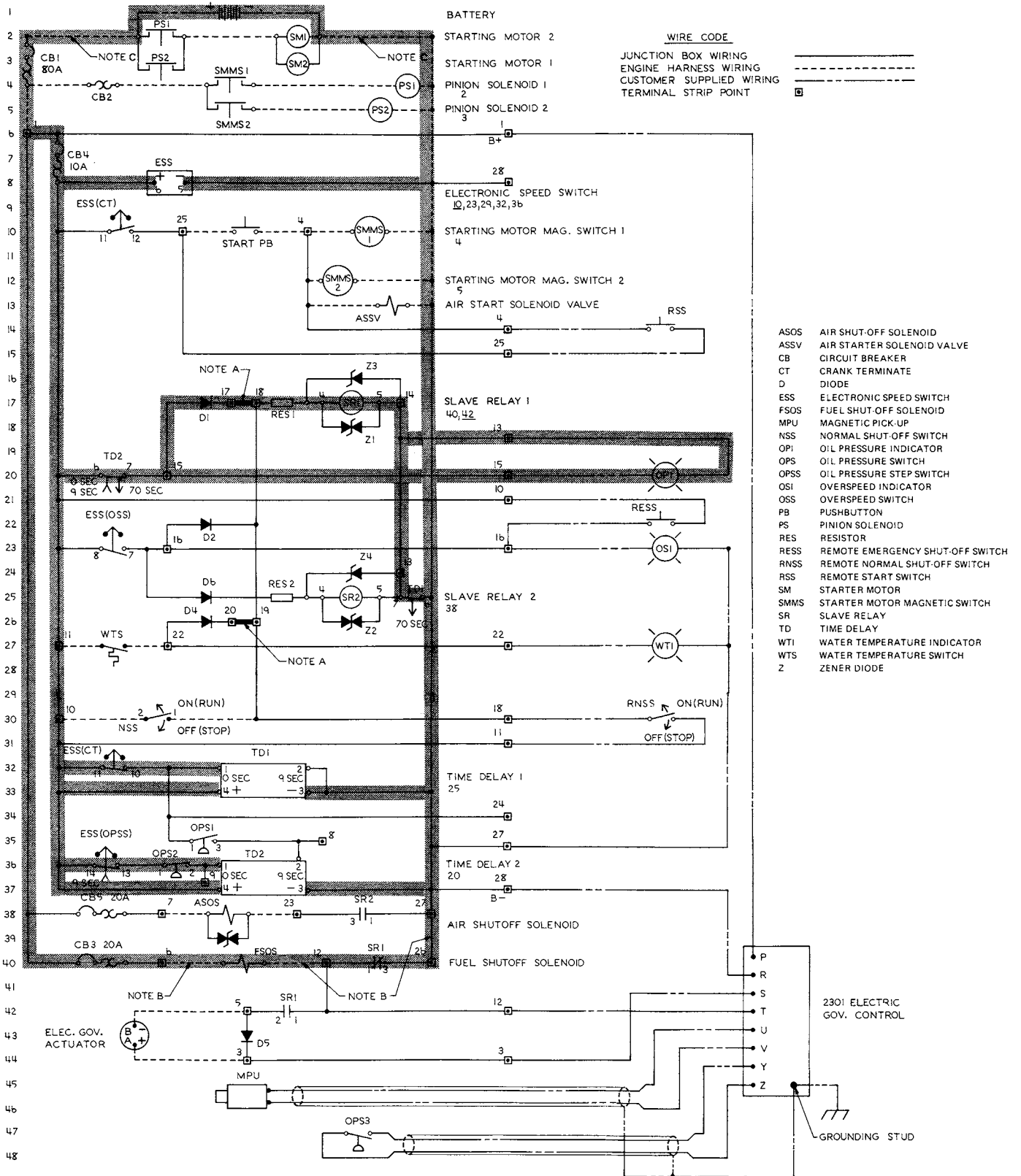

**Fig. 5**

**ENGINE RUNNING BELOW OIL STEP SPEED  
SETTING: NO FAULTS  
(OR JUST ACCELERATING THROUGH STEP  
SPEED)**

If engine continues to run below the step oil pressure speed setting, oil pressure step switch (OPSS) will remain open and will not complete the circuit to shutdown as shown in Fig. 6. Since oil pressure has increased enough to run at this speed (OPS1 switch is open), the engine can safely run at this speed and will not be shut down.

If the engine is accelerating through oil step speed setting, the circuit could still look as shown in Fig. 6. When engine speed is the same as (or goes above) the oil step speed setting engine oil pressure must increase to 280 kPa (40 psi) to open oil pressure switch (OPS2) within the 9 second time delay of the oil pressure step switch ESS(OPSS). The OPSS switch will close after 9 seconds and, if OPS2 is still closed, engine will shut down as shown in Fig. 5. If OPS2 has opened before OPSS has closed, engine will continue to run as shown in Fig. 4.



**ENGINE RUNNING BELOW OIL STEP SPEED SETTING: NO FAULTS  
(OR JUST ACCELERATING THROUGH STEP SPEED)**

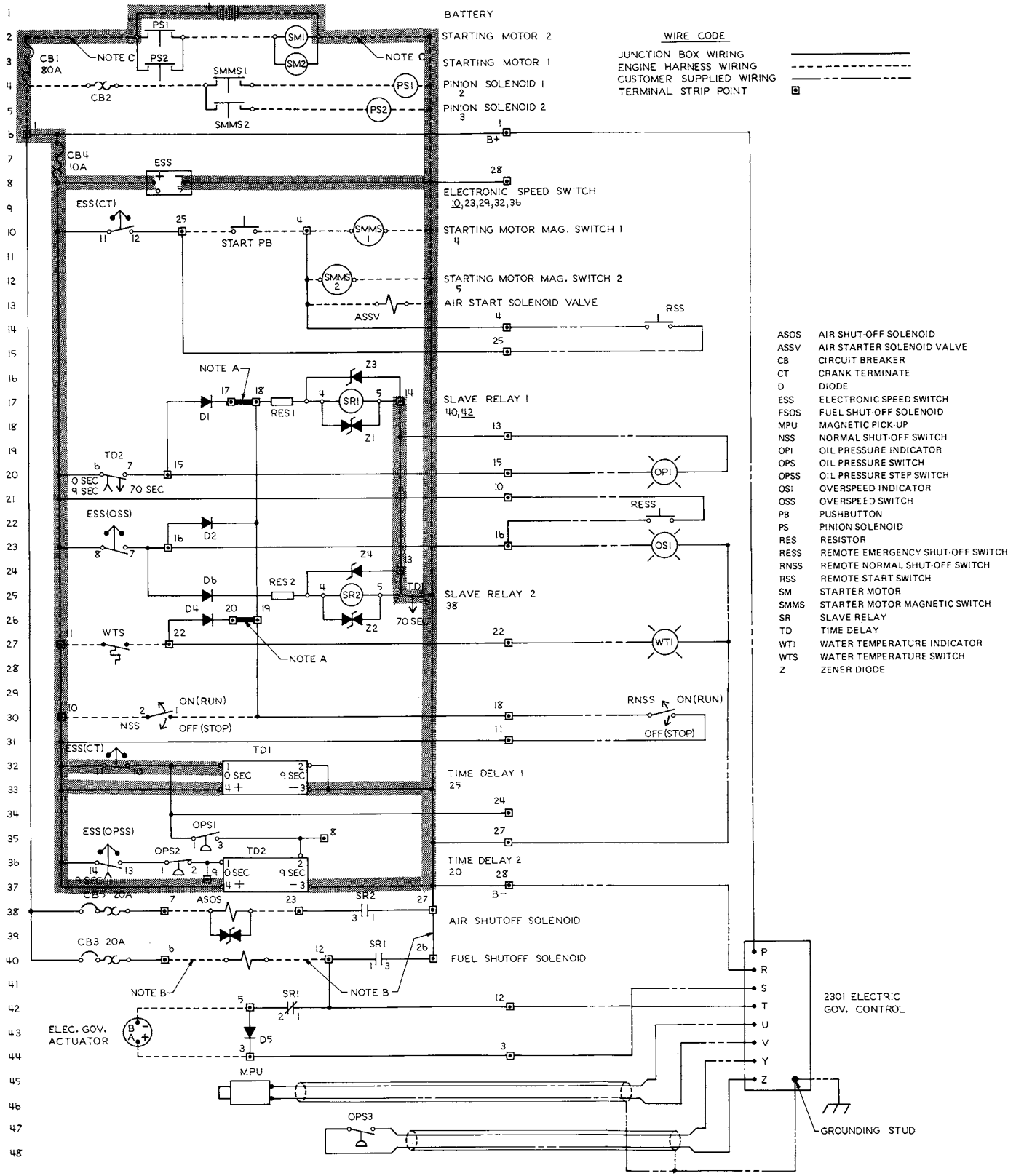

Fig. 6

**ENGINE SHUTDOWN DUE TO FAULT:  
LOW OIL PRESSURE  
(AT ENGINE SPEEDS BELOW OIL STEP SPEED  
SETTING)**

As engine is started and begins to run, crank terminate switch ESS(CT) **opens** across terminals ESS-11 and ESS-12 and **closes** across terminals ESS-11 and ESS-10. This immediately arms the system when current is sent to Control 1 (terminal 1) of time delay relay (TD1), which **closes** TD1 relay contacts (line 25) across terminals TD1-6 and TD1-7.

At the same time that TD1 is armed, there is current flow to Control 2 (terminal 2) of time delay relay (TD2) if oil pressure switch (OPS1) has not yet opened. The engine oil pressure has 9 seconds (from the time that TD1 is armed) to increase to the 140 kPa (20 psi) necessary to open OPS1. If OPS1 does **not open**, TD2 contacts will close across terminals TD2-6 and TD2-7 and slave relay (SR1) will be energized. SR1 relay contacts (line 42) will now **open** across terminals SR1-1 and SR1-2, and SR1 relay contacts (line 40) will **close** across terminals SR1-1 and SR1-3. The fuel shut-off solenoid (FSOS) is now energized, and will shut the fuel off to the engine.

If the engine had been running (with no faults) at a speed less than the oil step setting, and then lost engine oil pressure, the protection system would cause engine shutdown in the same way as shown in Fig. 7. OPS1 would close when oil pressure decreased to 105 kPa (15 psi), and 9 seconds later the engine would shut down.

**ENGINE SHUTDOWN DUE TO FAULT: LOW OIL PRESSURE  
(AT ENGINE SPEEDS BELOW OIL STEP SPEED SETTING)**

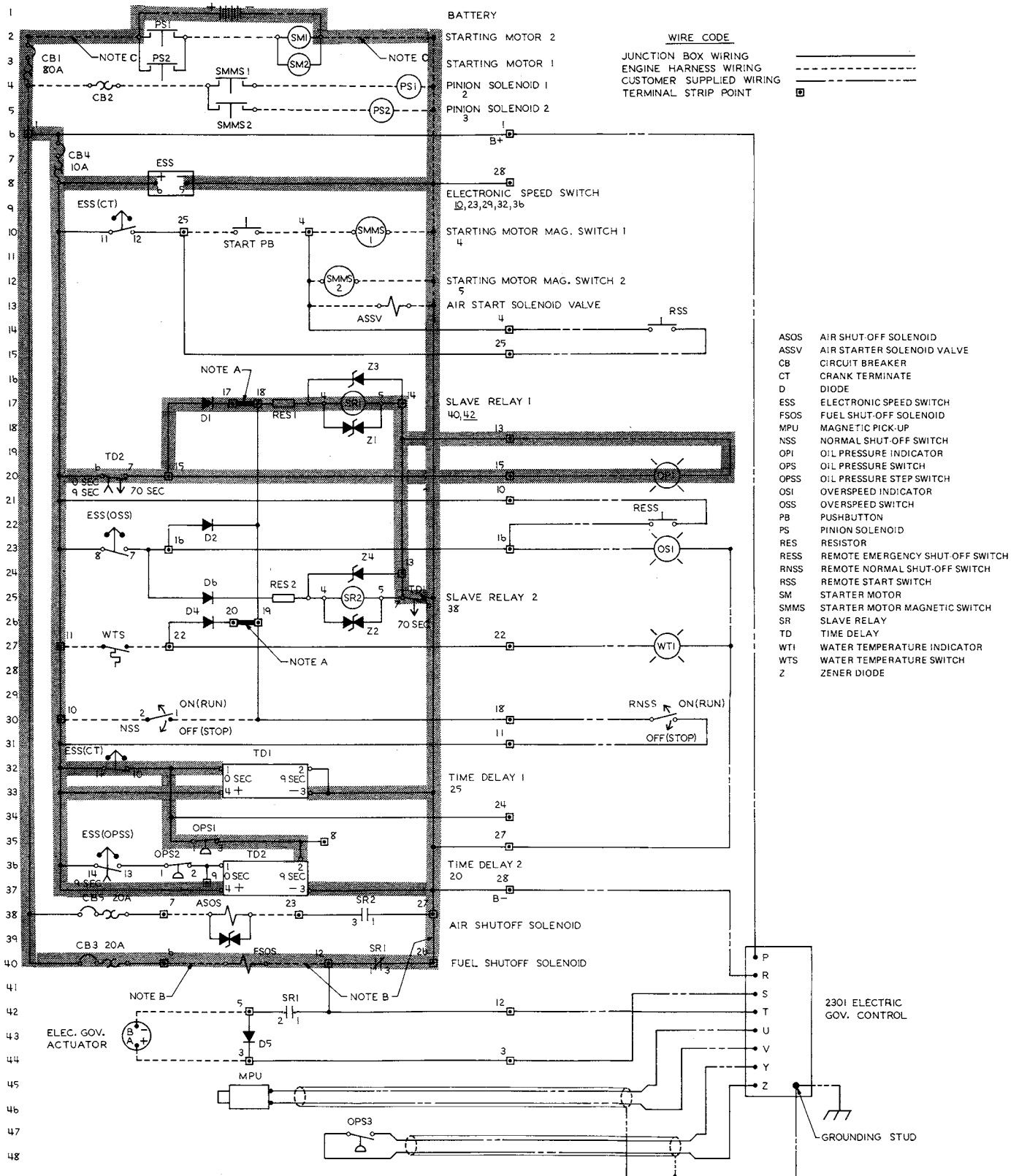

Fig. 7

**ENGINE SHUTDOWN DUE TO FAULT:  
COOLANT OVERHEATING**

The current flow of the circuit shown in Fig. 8 is for an engine running at a speed above the oil step setting with coolant temperature hot enough [ $98^{\circ}\text{C}$  ( $208^{\circ}\text{F}$ )] to close water temperature contactor switch (WTS). When WTS closes, this completes the circuit through slave relay (SR1) and through water temperature indicator (WTI). When slave relay (SR1) is energized, the contacts across terminals SR1-1 and SR1-3 will close. Now the fuel shut-off solenoid (FSOS) is energized to shut the fuel off to the engine.

After 70 seconds (when TD1 contacts open), the engine can be started again, but it will immediately be shutdown. The engine will not continue to run until coolant temperature cools down enough to open switch WTS.

NOTE: Engine shutdown caused by coolant overheating will also be the same if the engine is running at a speed below the oil step setting.

ENGINE SHUTDOWN DUE TO FAULT: COOLANT OVERHEATING

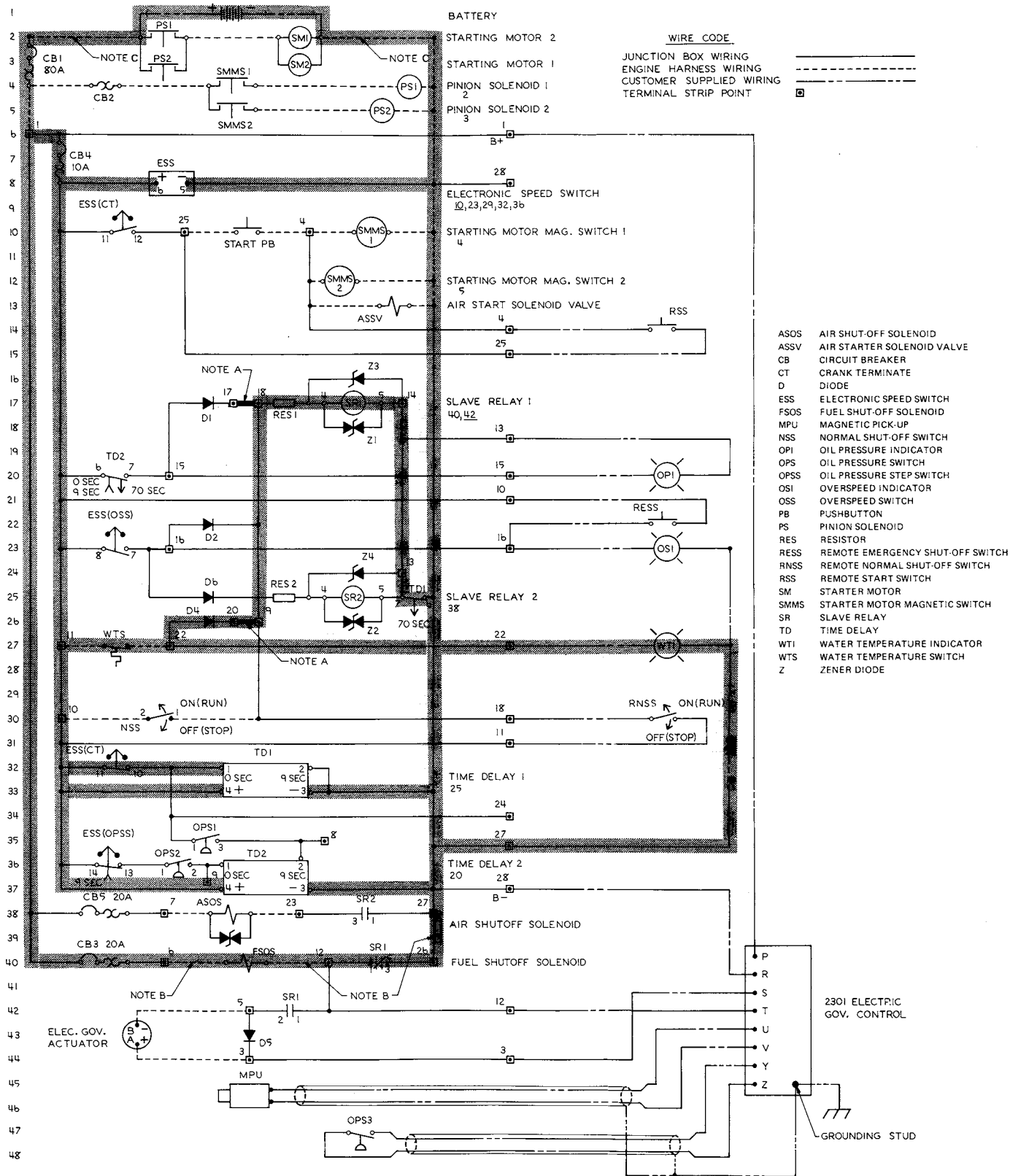

Fig. 8

### **ENGINE SHUTDOWN DUE TO FAULT: ENGINE OVERSPEED**

When engine speed increases above the overspeed setting (118% of rated speed) of the electronic speed switch (ESS), the overspeed switch ESS(OSS) will close across terminals ESS-7 and ESS-8 (line 23). This completes the circuit from the battery through overspeed indicator (OSI) and also through both slave relays (SR1 and SR2) as shown in Fig. 9.

Both slave relays (SR1 and SR2) are now energized at the same time. SR2 contacts will **close** across terminals SR2-1 and SR2-3 to activate air shut-off solenoid (ASOS). ASOS will now shut the inlet air off to the engine. At the same time, SR1 contacts **open** across terminals SR1-1 and SR1-2 (Line 42) and **close** across terminals SR1-1 and SR1-3 (line 40). The fuel shut-off solenoid (FSOS) is now activated, and will shut the fuel off to the engine.

A reset button on the ESS must be pushed to open the overspeed switch ESS(OSS), and the air shut-off lever (at top of air inlet housing) must be manually reset before the engine will run.

ENGINE SHUTDOWN DUE TO FAULT: ENGINE OVERSPEED

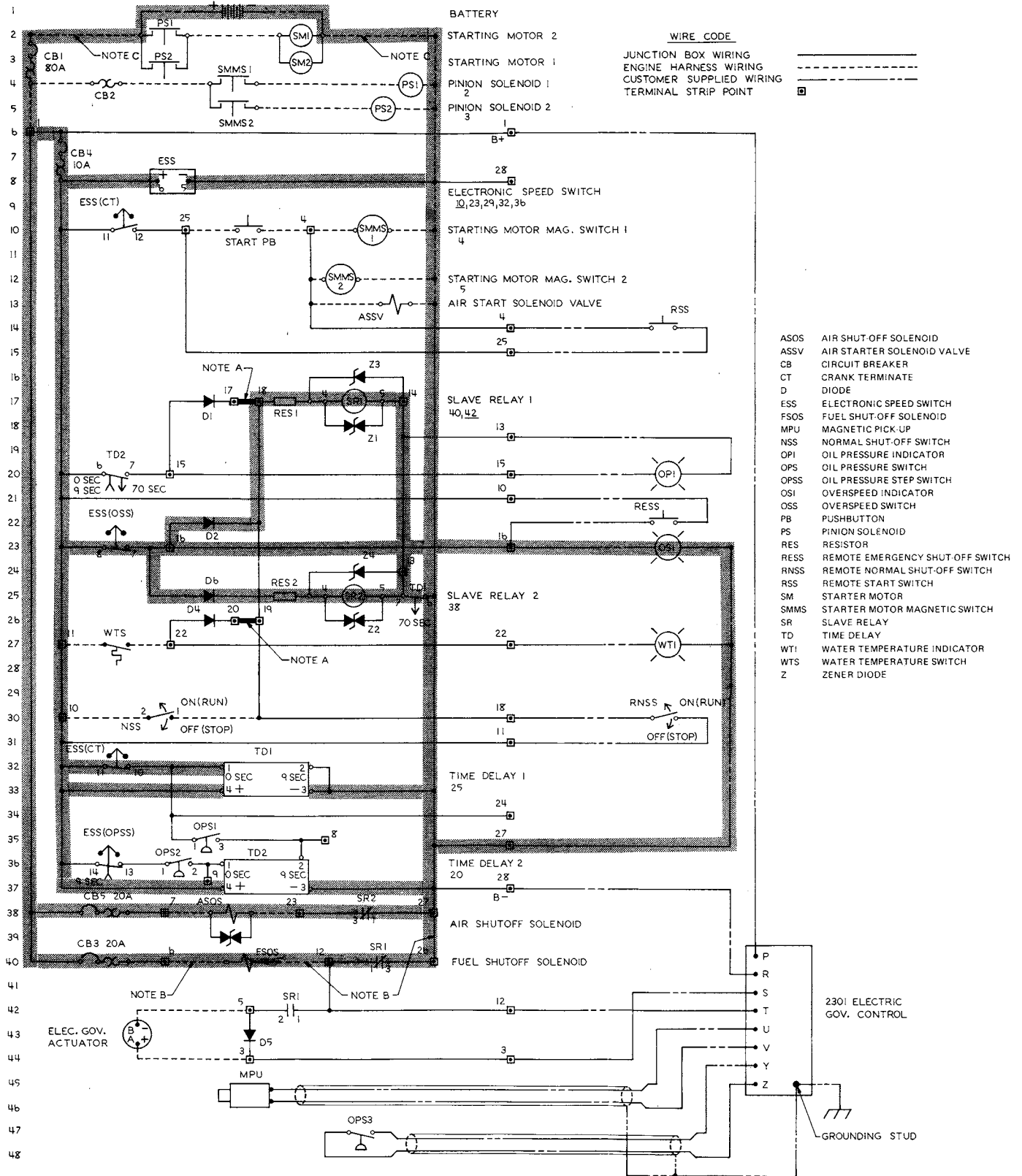

Fig. 9

**SHUTDOWN SYSTEM WITH 2301 ELECTRIC GOVERNOR CONTROL: NO FAULTS**

When the 2301 Electric Governor Control (EGC) is used, all systems of the electronic speed switch (ESS) are activated the same way as shown with a 3161, UG8D or a UG8L governor. The only difference in the circuit is that the fuel shut-off solenoid (FSOS) at line 40 is not used, and a jumper between terminal 26 and 27 is not used.

With the circuit shown in Fig. 10, current normally flows through electric governor actuator (EGA). When a fault in the system causes current to energize slave relay (SR1), the contacts open across terminals SR1-1 and SR1-2 (line 42) and close across terminals SR1-1 and SR1-3 (line 40).

When SR1 contacts open across terminals SR1-1 and SR1-2, the current can no longer flow through the EGA. The mechanical spring load in the EGA system will now move the fuel control rod to shut the fuel off to the engine.

NOTE: Except for the differences shown above, all fault circuits for the ESS system are the same for the EGC as those shown in Fig. 5 through Fig. 9 for the 3161 and UG8 governors.



**SHUTDOWN SYSTEM WITH 2301 ELECTRIC GOVERNOR CONTROL: NO FAULTS  
(CIRCUIT SHOWN AT RATED SPEED)**

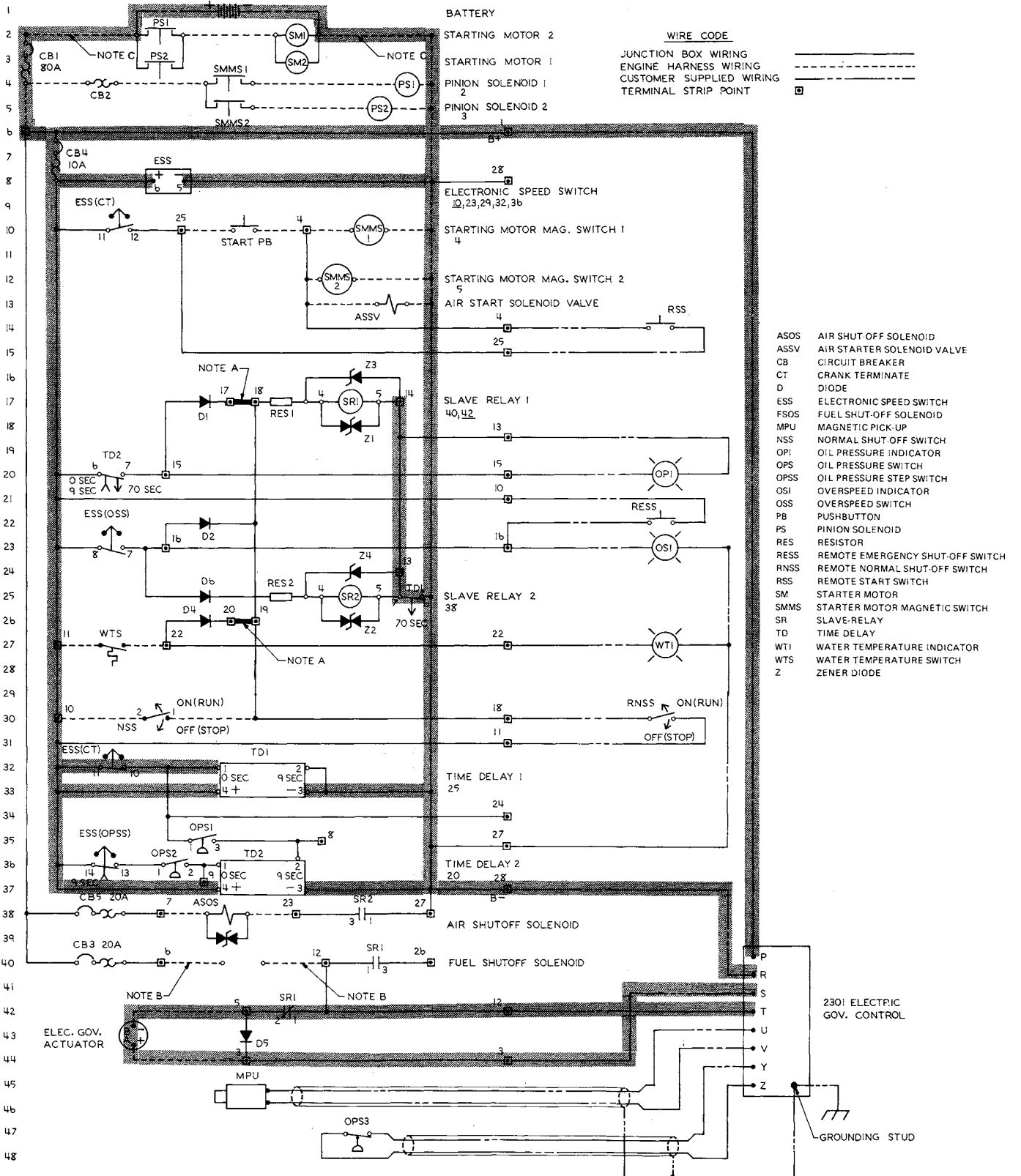

**Fig. 10**

## ELECTRIC PROTECTIVE SYSTEM FUNCTIONAL TEST

These tests are to be performed on an engine that is started for the first time and at recommended check intervals. They consist of quick and easy procedures for each system that can immediately identify if there is a problem in that system with a minimum amount of test time. If a problem is found, go to the correct chart of the more specific troubleshooting procedures.

Check each system of the engine as shown to verify if all components of the shut-off system works properly. To find the correct engine speed, make reference to SPEED SPECIFICATION CHART.

### TEST I. OVERSPEED (AIR AND FUEL SHUTOFF)

STEP	RUN ENGINE AT:	ACTION	CORRECT RESULT
A.	25 ± 5 rpm Less Than Verify rpm (75% Overspeed)	Press 75% Verify Button	No Engine Shutdown
B.	25 ± 5 rpm More Than Verify rpm (75% Overspeed)	Press 75% Verify Button	Air and Fuel Shut-off
C.	Manually Reset Air Shut-off Lever At Top Of Air Inlet Housing and Press ESS Reset Button.		

### TEST II. NORMAL SHUTOFF SWITCH (FUEL SHUTOFF ONLY)

STEP	RUN ENGINE AT:	ACTION	CORRECT RESULT
A.	Any Speed Above Crank Terminate rpm	Push Shut-off Switch To OFF Position	Fuel Shut-off

### TEST III. OIL PRESSURE (FUEL SHUTOFF ONLY)

STEP	RUN ENGINE AT:	ACTION	CORRECT RESULT
A.	25 ± 5 rpm Less Than Oil Step Speed	Put Jumper Across Terminal 1 & Terminal 2 of Oil Pressure Switch OPS2	No Engine Shutdown
B.	—	Remove OPS2 Jumper	—
C.	Same Speed as Step A	Put Jumper Across Terminal 1 & Terminal 3 of Oil Pressure Switch OPS1	Fuel Shut-off After 9 ± 1 Seconds
D.	—	Remove Jumper From OPS1	—
E.	25 ± 5 rpm More Than Oil Step Speed	After 9 Seconds, Put Jumper Across Terminal 1 and Terminal 2 (OPS2)	Fuel Shut-off
F.	Remove Jumper From OPS2 Terminals 1 and 2		

### TEST IV. WATER TEMPERATURE (FUEL SHUTOFF ONLY)

STEP	RUN ENGINE AT:	ACTION	CORRECT RESULT
A.	Any Speed Above Crank Terminate rpm	Put Jumper Across Terminals TS11 & TS 22	Fuel Shut-off
B.	Remove Jumper From Terminals TS11 and TS 22		

## SPEED SPECIFICATION CHART

SPEED SPECIFICATION CHART (RPM)				
TYPICAL RATED ENGINE SPEED	OVERSPEED SETTING ( $\pm 25$ ) NOTE E	75% OVERSPEED VERIFY ( $\pm 25$ ) NOTE C	OIL STEP SPEED SETTING	CRANK TERMINATE
1800	2125	1600	1125	600
1600	1890	1415	1125	600
1500	1775	1325	1125	600
1300	1535	1150	750	400
1200	1415	1060	750	400
1000	1180	885	750	400
900	1065	800	750	400

# INTRODUCTION TO THE TROUBLESHOOTING GUIDE

The troubleshooting guide, when followed exactly as shown, can be an aid for the serviceman to find if a problem exists, and to find the cause of the existing problem.

## **SYSTEM TROUBLESHOOTING CHARTS AND PROCEDURES**

The troubleshooting charts that follow show a definite sequence to be followed for a logical, one by one elimination of many variables. There are specific procedures written to check out different components of the system, and they can be found at the end of the troubleshooting charts. When the chart makes reference to a specific procedure, do this procedure before proceeding any farther in the chart.

When a problem is found and corrected, always check the system again by use of verify procedure as shown at bottom of charts.

Some areas of the charts say to go to an alphabetical letter. When told to go to this specific letter, find this letter with a circle around it in the chart. Follow the test procedures from this point to the bottom of the chart.

## PROBLEM IDENTIFICATION INDEX

<b>Engine Will Not Start:</b>	<b>Chart</b>	<b>Page</b>
Overspeed Switch Closed (Battery Voltage at Speed Switch Terminal ESS-7) .....	B	33
Overspeed Trips (Light ON) When Power is First Applied With Engine Stopped .....	B	33
Starter Motor Cranks Intermittently .....	C	34
Starter Motor Cranking Stops Too Soon .....	C	34
Starter Motor Will Not Crank .....	C	35
 <b>Engine Runs, But There is Still a Problem:</b>		
Overspeed Trips (Light ON) at Wrong Speed .....	B	32
Overspeed Trips Intermittently (Light ON and OFF) With Engine Running .....	B	32
Overspeed Will Not Trip (Light OFF) During 75% Overspeed Verify Test .....	B	32
Starter Motor Cranking Stops at Wrong Speed .....	C	34
Starter Motor Will Not Disengage .....	C	35
 <b>Engine Will Not Shut Down:</b>		
Engine RPM is Above Oil Step RPM Setting and Engine Oil Pressure is Lower Than Preset Value (35 psi), But No Engine Shutdown .....	D	36
Engine RPM is Below Oil Step RPM Setting and Engine Oil Pressure is Lower Than Preset Value (15 psi), But No Engine Shutdown .....	D	36
Normal Shutoff Switch in OFF Position (While Operating at Any Speed Greater than Crank Terminate), But No Engine Shutdown .....	A	31
Overspeed Trips (Light ON), But No Engine Shutdown .....	B	33

## SYSTEM TROUBLESHOOTING CHARTS AND PROCEDURES

### PRELIMINARY CHECKS TO TROUBLESHOOTING PROCEDURES

NOTE A: BEFORE STARTING ANY SPECIFIC TROUBLESHOOTING PROCEDURES, FIRST CHECK THE ITEMS THAT FOLLOW:

- CHECK THE THREE CIRCUIT BREAKERS ON THE FRONT COVER OF THE JUNCTION BOX. IF ANY OF THE PUSHBUTTONS HAVE MOVED TO THE EXTENDED POSITION, PUSH THAT BUTTON BACK IN TO RESET THE CIRCUIT BREAKER.
- CHECK DC VOLTAGE LEVEL BETWEEN SPEED SWITCH TERMINALS ESS-5 and ESS-6 (ACCEPTABLE VOLTAGE LEVELS 8 to 40 VDC).
- CHECK FOR LOOSE WIRE CONNECTORS, DAMAGED WIRES OR LOOSE WIRES AT SCREW TERMINAL CONNECTIONS.

SYSTEM  
ARMING

OVERSPEED  
FUNCTION

CRANK  
TERMINATE  
FUNCTION

OIL STEP  
FUNCTION

NOTE B. Do Not Leave Starter Motor Engaged With Engine Running. Engines that have electric starter motor(s), or a DC actuated air starter motor, automatically disengage when crank termination rpm is reached. Positive (+) battery voltage is removed from the engine mounted or remote mounted starter controls when the normally closed crank termination contacts open. To perform test measurements, **one** of the methods that follow may be necessary to disengage the starter motor:

1. Disconnect wire at speed switch terminal ESS-12.

2. Manually disengage by installing a toggle switch to control the electric starter motor magnetic switch (install the switch in series with the magnetic switch coil lead).

3. Manually disengage by installing a toggle switch to control the air starter solenoid valve (install the switch in series with either of the solenoid valve leads).

NOTE: For wiring diagrams and schematics, make reference to Wiring Diagrams Section.

# TROUBLESHOOTING (SYSTEM ARMING)

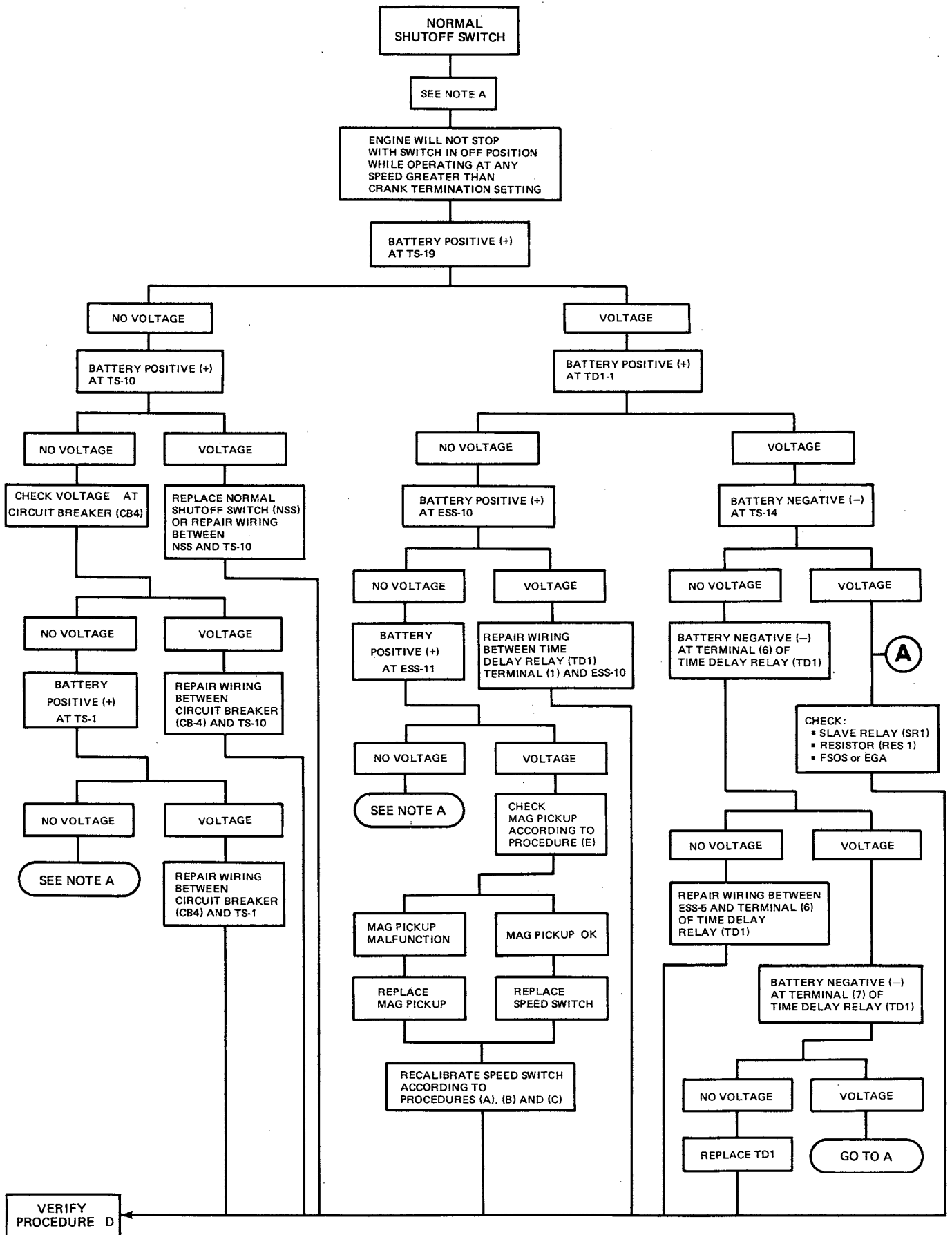

**CHART A**

# TROUBLESHOOTING (OVERSPEED)

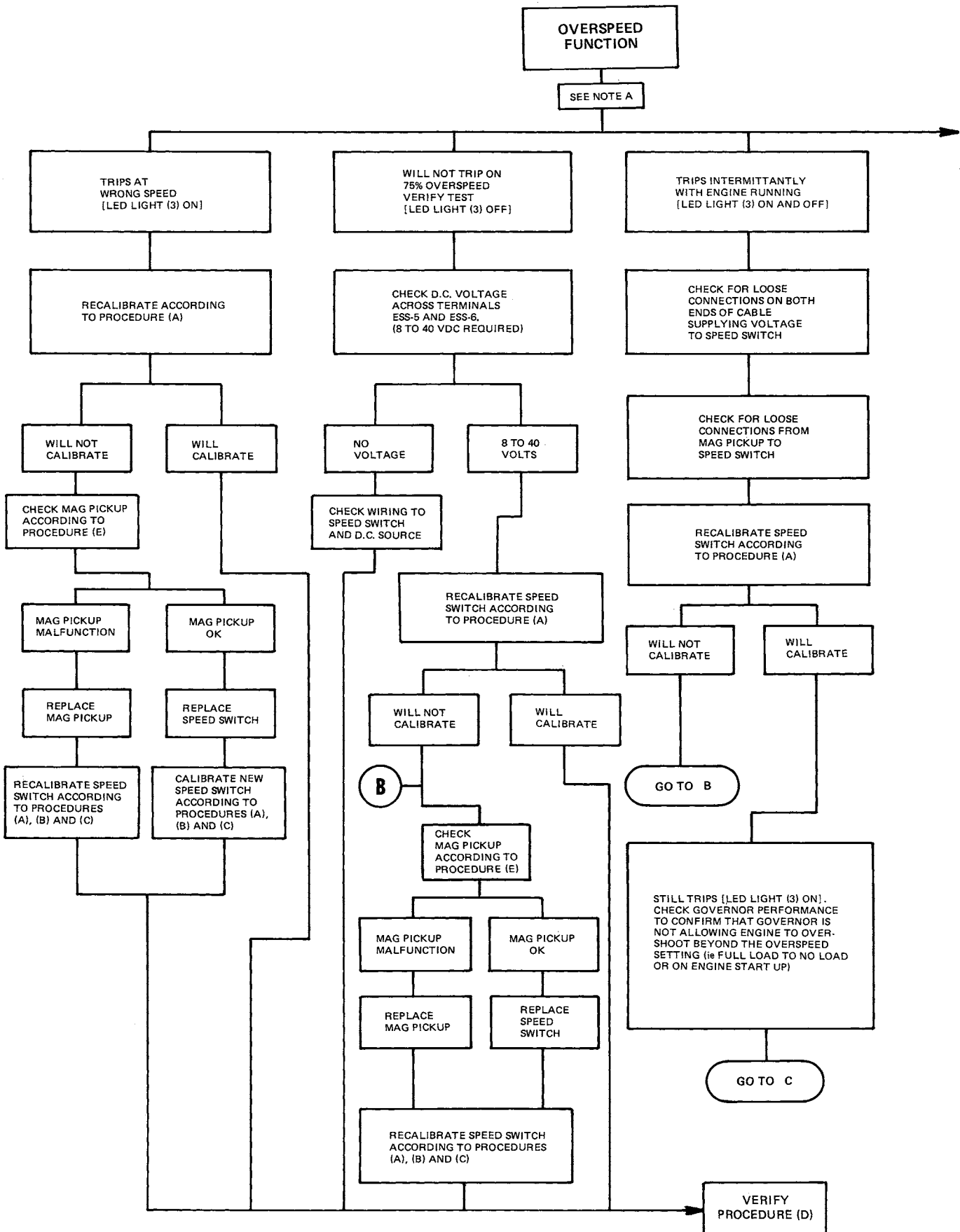

**CHART B**



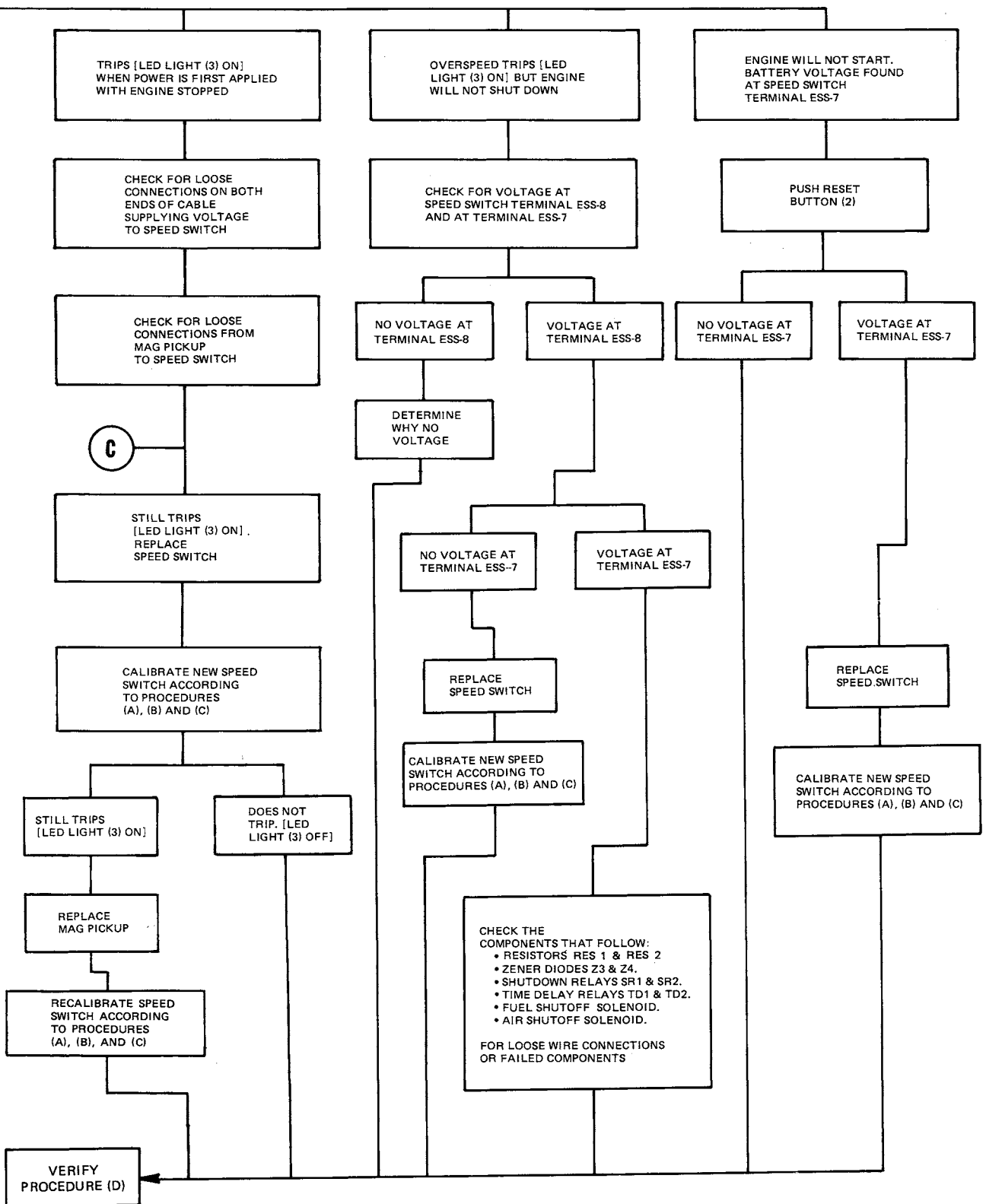

CHART B (Continued)

# TROUBLESHOOTING (CRANK TERMINATE)

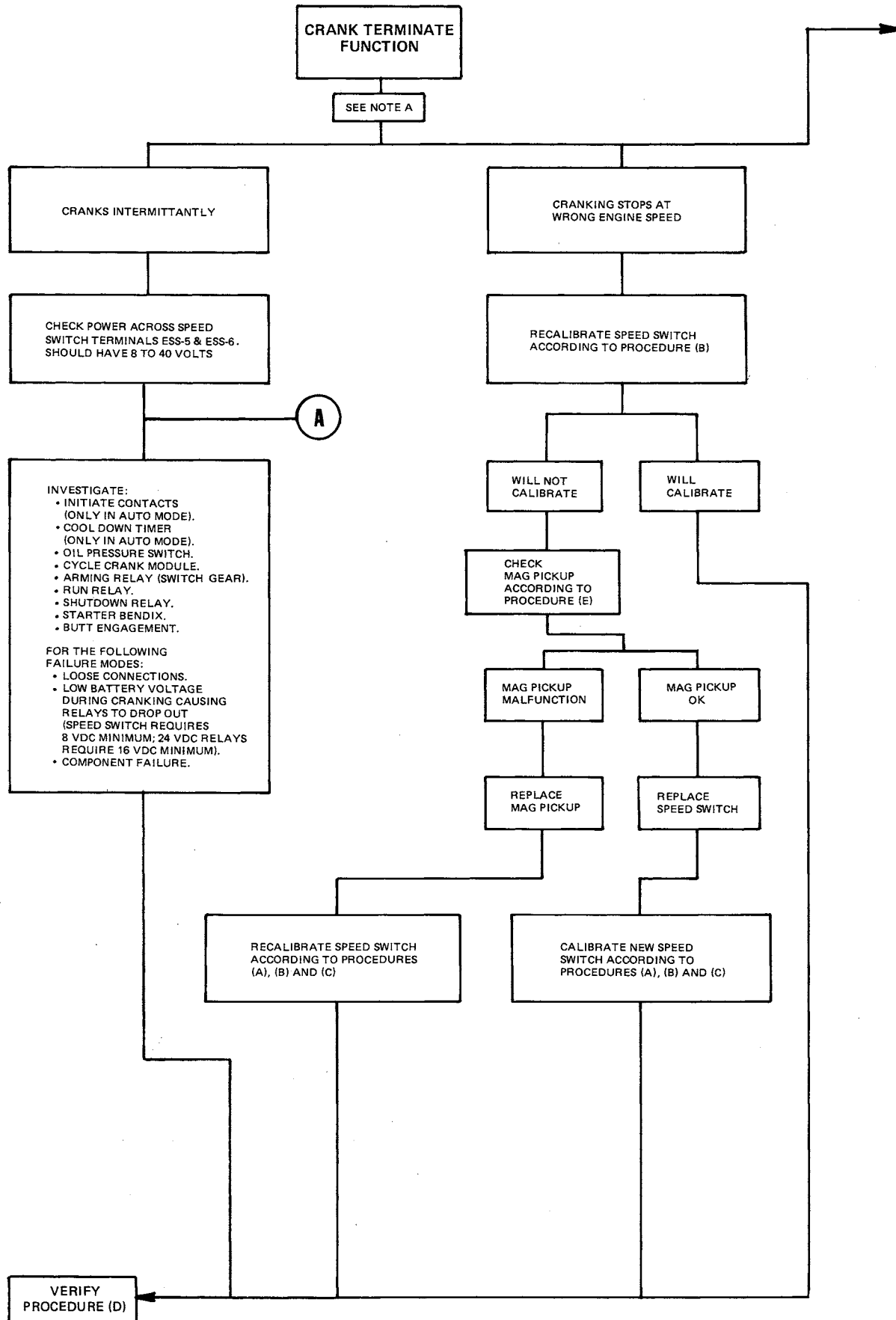

CHART C

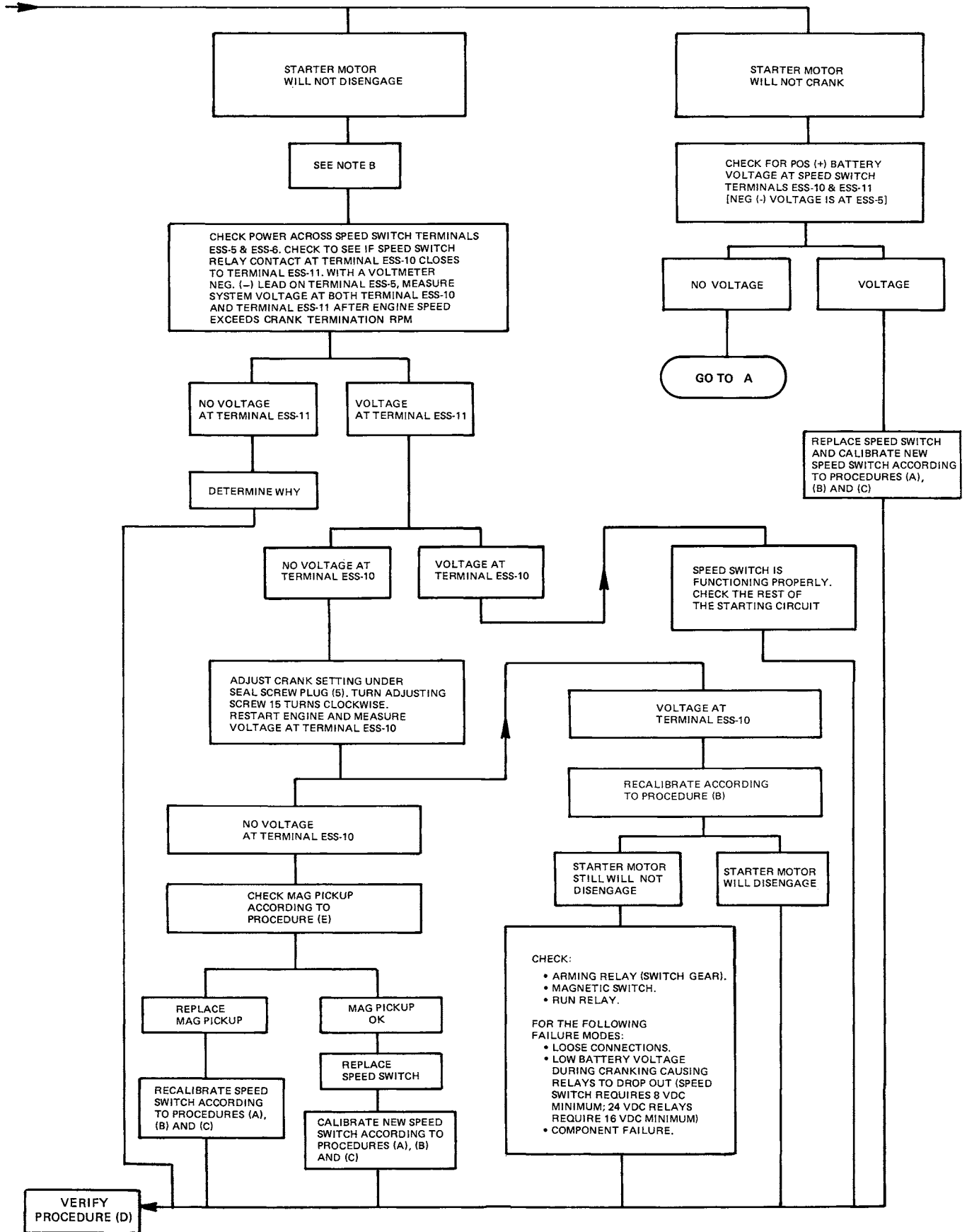
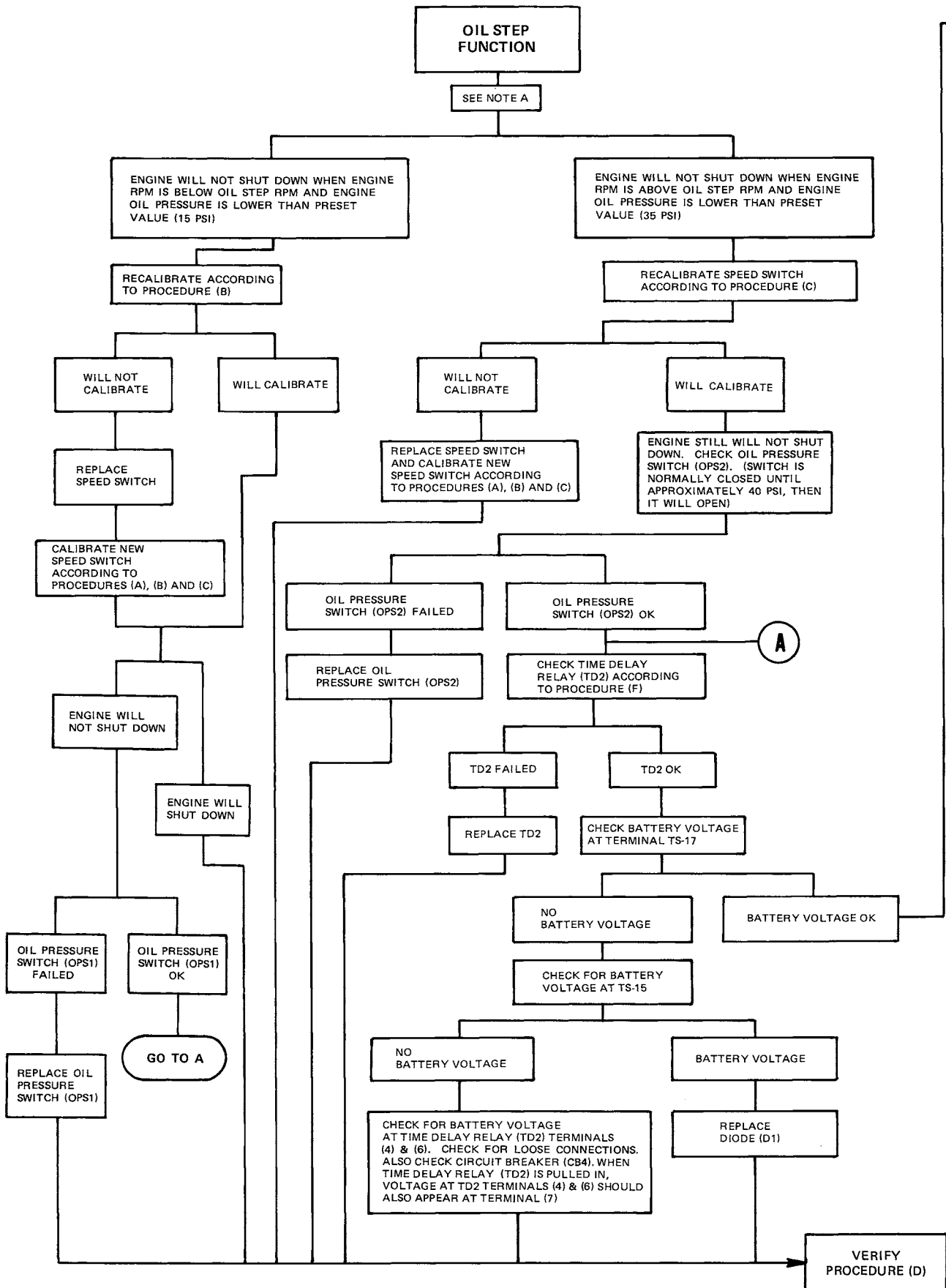

CHART C (Continued)

# TROUBLESHOOTING (STEP OIL PRESSURE)



**CHART D**

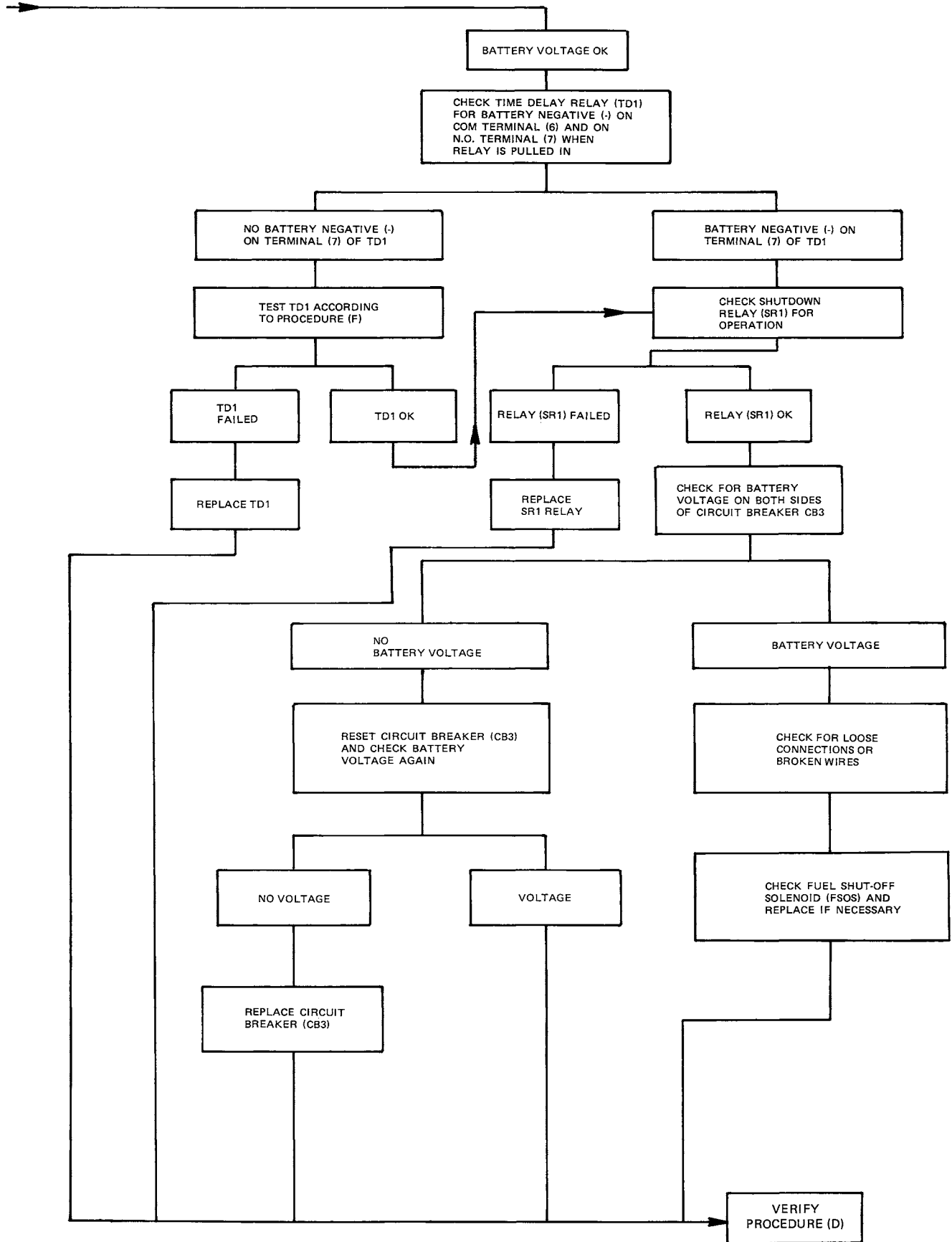
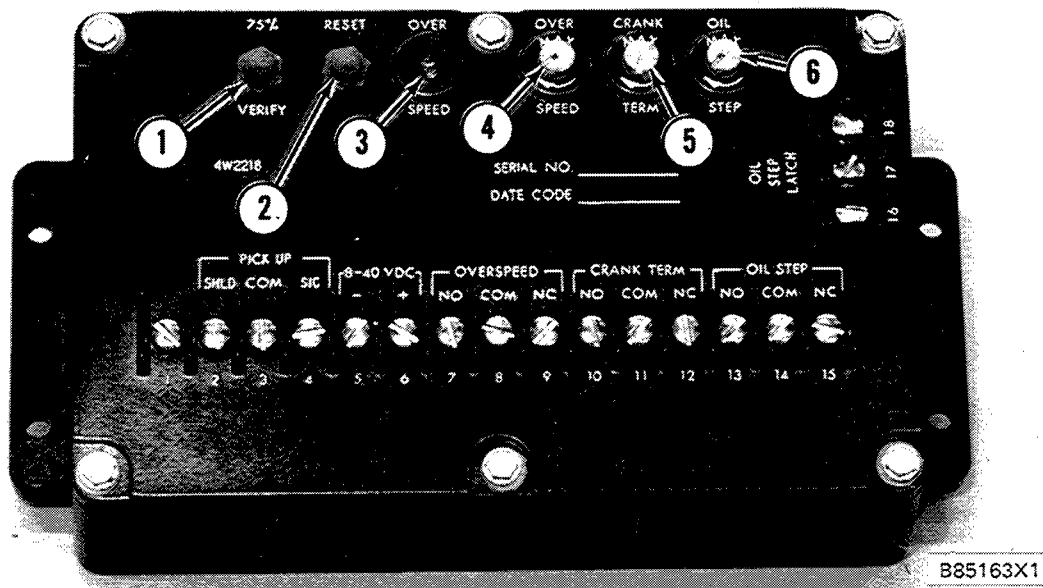

CHART D (Continued)

## PROCEDURE A



4W2218 ELECTRONIC SPEED SWITCH (ESS)

1. Verify button.
2. Reset button.
3. "LED" overspeed light.
4. Seal screw plug (overspeed).
5. Seal screw plug (crank terminate).
6. Seal screw plug (oil step).

### OVERSPEED SETTING CALIBRATION

1. Remove lockwire and seal from seal screw plugs (4), (5) and (6). Remove seal screw plug (4) from access hole for overspeed adjustment screw.
2. Use a small screwdriver and lightly turn overspeed adjustment potentiometer twenty turns in the direction of "MAX ARROW" (clockwise).

NOTE: The overspeed adjustment screw is made so that it can not cause damage to the potentiometer, or be removed, if the adjustment screw is turned too many turns in either direction.

3. Run engine at 75% of desired overspeed setting rpm. Make reference to the SPEED SPECIFICATION CHART (Part of PROCEDURE D).
4. With engine at 75% of overspeed setting rpm, push VERIFY button (1) and hold in. Turn overspeed adjustment potentiometer in the direction opposite of "MAX ARROW" counterclockwise) slowly until "LED" over-

speed light (3) comes on. Engine will shutdown if speed switch is connected to the fuel shutoff solenoid and/or air inlet shutoff solenoid.

5. To reset speed switch, push in reset button (2). Air inlet shutoff must be manually reset.
6. Slowly turn overspeed adjustment potentiometer approximately one turn clockwise and do Steps 3, 4 and 5 again.

NOTE: More adjustment may be needed to get the correct setting. Turn adjustment potentiometer clockwise to increase speed setting, and counterclockwise to decrease speed setting. Turn adjustment potentiometer very slowly only a small amount at a time until adjustment is correct.

7. When the speed setting is correct, install seal screw plug (4) in overspeed adjustment access hole. Tighten screw to a torque of  $0.20 \pm 0.03$  N·m ( $2 \pm .3$  lb. in.). Install the lockwire and seal (if crank termination and oil step adjustments are complete).

## PROCEDURE B

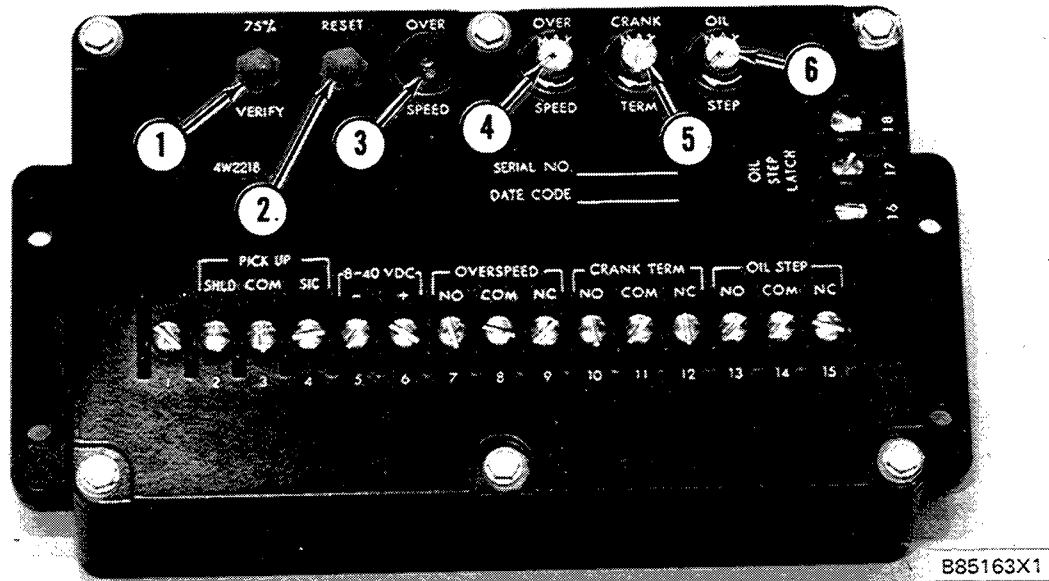

4W2218 ELECTRONIC SPEED SWITCH (ESS)

1. Verify button. 2. Reset button. 3. "LED" overspeed light. 4. Seal screw plug (overspeed). 5. Seal screw plug (crank terminate). 6. Seal screw plug (oil step).

### CRANK TERMINATE SPEED ADJUSTMENT

1. Remove lockwire and seal from seal screw plug (4), (5) and (6). Remove seal screw plug (5) from the access hole for crank terminate adjustment screw.
2. Use a small screwdriver and lightly turn the crank terminate adjustment potentiometer twenty turns in the direction of "MAX ARROW" (clockwise).

NOTE: The crank terminate adjustment screw is made so that it can not cause damage to the potentiometer, or be removed, if the adjustment screw is turned too many turns in either direction.

3. Turn the crank terminate adjustment potentiometer twelve turns in a direction opposite of "MAX ARROW" (counterclockwise) for an approximate crank terminate setting.
4. Connect a voltmeter (6V7070 Multimeter or a voltmeter of same accuracy) with the positive lead at ESS-12 and the negative lead at ESS-5. Start the engine and make a note of the speed at

which the system voltage is canceled (this is the speed at which the DC starter system disengages). See the SPEED SPECIFICATION CHART (Part of PROCEDURE D) for the correct crank terminate speed.

NOTE: If setting is not correct, do Steps 5, 6 and 7. If setting was correct, go to Step 7.

5. Stop the engine and turn the crank terminate adjustment potentiometer one full turn in the correct direction (clockwise to increase and counterclockwise to decrease).
6. With the voltmeter still connected as in Step 4, start the engine and make a note of the speed at which the system voltage is canceled (this is the speed at which the DC starter system disengages). If needed, make more small adjustments until the crank terminate speed is correct.
7. Install seal screw plug (5) in crank terminate adjustment access hole. Tighten to a torque of  $0.20 \pm 0.03 \text{ N}\cdot\text{m}$  ( $2 \pm .3 \text{ lb. in.}$ ). Install the lockwire and seal (if overspeed and oil step adjustments are complete).

## PROCEDURE C

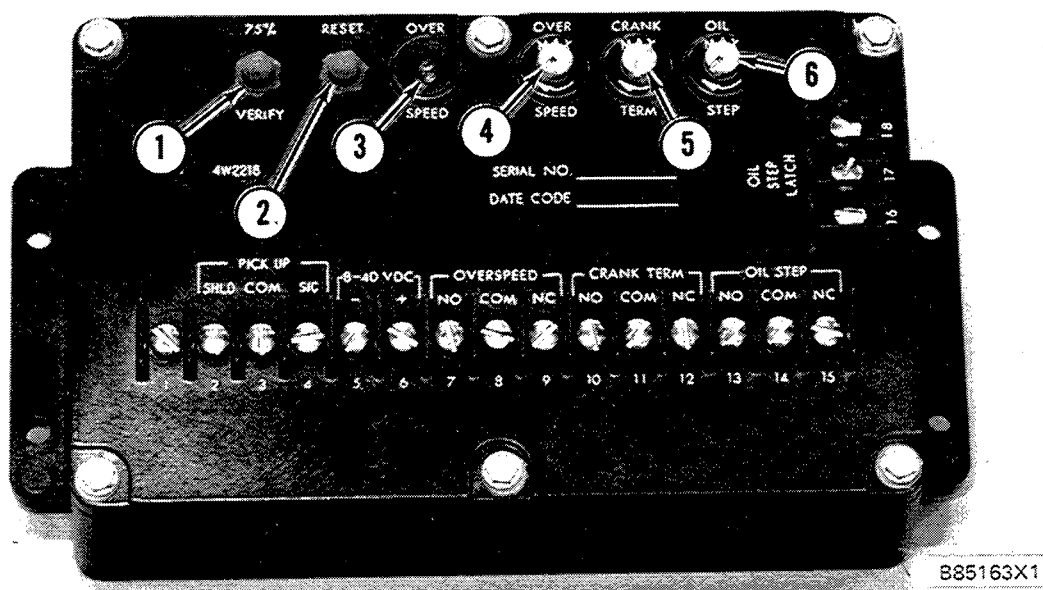

4W2218 ELECTRONIC SPEED SWITCH (ESS)

1. Verify button. 2. Reset button. 3. "LED" overspeed light. 4. Seal screw plug (overspeed). 5. Seal screw plug (crank terminate). 6. Seal screw plug (oil step).

### OIL STEP CALIBRATION

1. Remove the lockwire and seal from seal screw plugs (4), (5) and (6). Remove seal screw plug (6) from access hole for the oil step adjustment screw.
2. Use a small screwdriver and lightly turn oil step adjustment potentiometer 20 turns in the direction opposite of "MAX ARROW" (counterclockwise). This will lower the oil step speed setting to its lowest value.

NOTE: The oil step adjustment screw is made so it can not cause damage to the potentiometer, or be removed, if the adjustment screw is turned too many turns in either direction.

3. Use a 6V7070 Multimeter (or a voltmeter of same accuracy) to check for positive (+) voltage at terminal ESS-13 [negative (-) voltage is at terminal ESS-5].
4. Make reference to SPEED SPECIFICATION CHART (Part of PROCEDURE D). For a

particular engine rating, find the specified rpm in column for Oil Step Speed Setting. Run the engine at this specified rpm.

5. With the engine running, look into the oil step adjustment access hole. A red "LED" (light emitting diode) light will be on. After an 8 to 10 second delay, positive (+) voltage will be seen at terminal ESS-13. Now turn the oil step adjustment potentiometer clockwise until the red light in the oil step access hole goes out. When the light goes out, this indicates that the oil step rpm setting is above the present running rpm of the engine. Slowly turn the adjustment potentiometer counterclockwise until the light comes back on. After an 8 to 10 second delay, positive (+) voltage will be seen at terminal ESS-13.
6. When the oil step setting is correct, install seal screw plug (6) into the adjustment access hole for the oil step function. Tighten plug to a torque of  $0.20 \pm 0.03 \text{ N}\cdot\text{m}$  ( $2 \pm .3 \text{ lb. in.}$ ). If all other adjustments are complete (overspeed and crank terminate), install lockwire and seal.



# PROCEDURE D

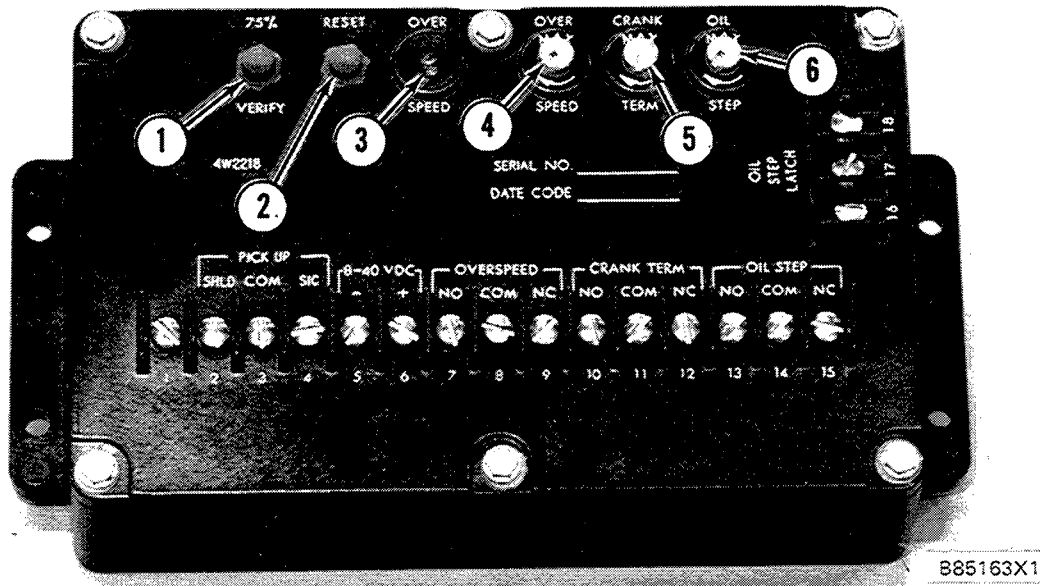

4W2218 ELECTRONIC SPEED SWITCH (ESS)

- 1. Verify button. 2. Reset button. 3. "LED" overspeed light. 4. Seal screw plug (overspeed). 5. Seal screw plug (crank terminate). 6. Seal screw plug (oil step).

## OVERSPEED VERIFY TEST

1. Run the engine at rated speed and push verify button (1) in for a moment. This will cause the speed switch to activate and shutdown the engine.

NOTE: Any time the engine speed is 75% or more of the overspeed setting, the engine will shutdown if the verify button is pushed.

EXAMPLE: For an engine with a rated speed of 1800 rpm, the overspeed setting is 2125 rpm (see SPEED SPECIFICATION CHART and Note E). The overspeed verify test will shutdown the engine at 75% ( $\pm 25$  rpm) of the overspeed setting of 2125 rpm. In this example, 75% of 2125 rpm is approximately 1600 rpm. If the verify button is pushed at an engine speed of approximately 1600 rpm or above, the engine will shutdown.

The "LED" overspeed light (3) will come on and stay on until the reset button is pushed after an overspeed switch shutdown. To restart the engine, push in reset button (2) for a moment. This will reset the speed switch, and the "LED" overspeed light (3) will go off. The air inlet shutoff lever must now be manually reset before the engine can be started.

NOTE C: To verify overspeed shutdown system operation, push in the VERIFY button for a moment. The engine must shutdown at 75% or more of overspeed setting.

NOTE D: Input Voltage: Maximum 40 VDC; Minimum 8 VDC.

NOTE E: The engine overspeed setting rpm is 118% of rated engine rpm.

SPEED SPECIFICATION CHART (RPM)				
TYPICAL RATED ENGINE SPEED	OVERSPEED SETTING ( $\pm 25$ ) NOTE E	75% OVERSPEED VERIFY ( $\pm 25$ ) NOTE C	OIL STEP SPEED SETTING	CRANK TERMINATE
1800	2125	1600	1125	600
1600	1890	1415	1125	600
1500	1775	1325	1125	600
1300	1535	1150	750	400
1200	1415	1060	750	400
1000	1180	885	750	400
900	1065	800	750	400

## PROCEDURE E

### MAGNETIC PICKUP VERIFY

1. Connect a 6V7070 Multimeter (or a voltmeter of same accuracy) to electronic speed switch common terminal (ESS-3) and signal terminal (ESS-4). Set the meter voltage scale to a scale greater than 1.5 VAC. Start the engine and run at idle rpm or 600 rpm (whichever is greater).

If the measured voltage is 1.5 VAC or **more**, the operation of the magnetic pickup is correct. If measured voltage is **less** than 1.5 VAC, go to Step 2.

2. Disconnect the wiring from the magnetic pickup and connect the voltmeter to magnetic pickup connector terminals 1 and 2. Set the voltmeter voltage scale to a scale greater than 1.5 VAC. Start the engine and run at idle rpm or 600 rpm (whichever is greater).

If the measured voltage is 1.5 VAC or **more**, repair or replace the wiring between the magnetic pickup and the electronic speed switch. If the measured voltage is **less** than 1.5 VAC, go to Step 3.

3. Remove magnetic pickup (2) from the engine flywheel housing (earlier location, front drive housing) and turn the flywheel until a gear tooth (5) is directly in the center of the threaded opening for the magnetic pickup. Install the magnetic pickup again in the threads of housing (6).

By hand, turn in a clockwise direction until the end of the magnetic pickup just makes contact with the gear tooth (5). Now turn the magnetic pickup back out  $\frac{1}{2}$  turn ( $180^\circ$  in the counterclockwise direction) to get the correct air gap [clearance dimension (1)]. Now tighten locknut (4) to a torque of  $68 \pm 13 \text{ N}\cdot\text{m}$  ( $50 \pm 10 \text{ lb. ft.}$ ).

NOTE: Do not let the magnetic pickup turn while locknut is tightened.

Do Step 2 again. If voltage is still **less** than 1.5 VAC, replace the magnetic pickup.

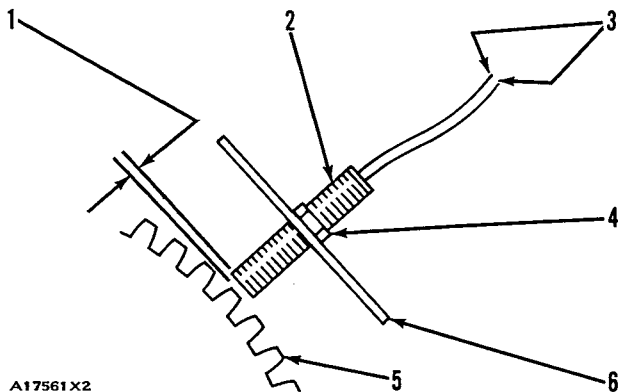

A17561 X2

MAGNETIC PICKUP

1. Clearance dimension. 2. Magnetic pickup. 3. Wires.
4. Locknut. 5. Gear tooth. 6. Housing.

# PROCEDURE F

## ON/OFF TIME DELAY (RELAY)

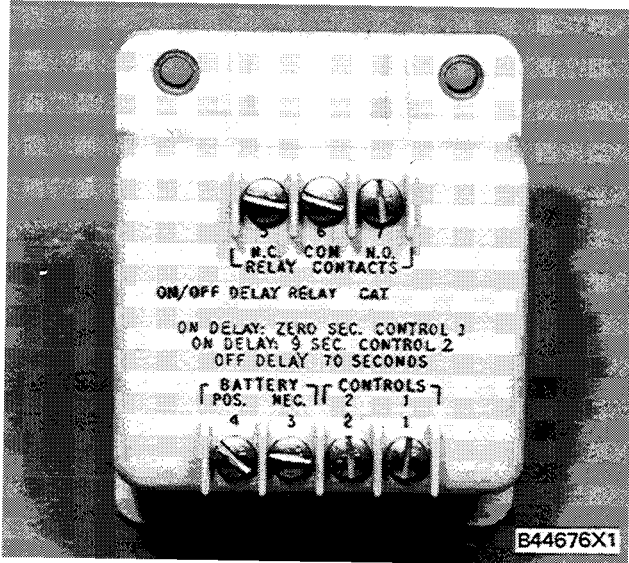

ON/OFF TIME DELAY (RELAY)

### Performance Check (either TD1 or TD2 relays can be checked with methods that follow)

#### A. Items Required For Check:

1. Battery or any D.C. source of 8 to 40 volts.
2. Voltmeter (6V7070 Multimeter or one of same accuracy).
3. Stop watch.

#### B. Bench Or Installed Test

Connect or verify source voltage to relay terminals 3 (-) and 4 (+) [if bench testing, also connect positive (+) voltage to relay terminal 6]. All connections must be maintained until tests are complete.

NOTE: There will be voltage when the relay is closed. When relay is open, there will be no voltage [voltage may be positive (+) or negative (-) when relay is tested on engine; when bench testing, voltage will always be positive (+)].

1. Use the voltmeter to verify chart that follows:

Terminals	Relay Position
5	Closed
7	Open

2. (a) Apply positive (+) source voltage to terminal 1 (either relay) and immediately verify the chart that follows (do not leave vol-

tage on terminal 1 for more than 60 seconds):

Terminals	Relay Position
5	Open
7	Closed

- (b) Remove positive (+) source voltage from terminal 1. Use a stop watch and check the time from the moment of removal to verify chart that follows:

Terminals	Delay Time to Function	
	0 to 60 Secs.	After 80 Secs.
5	Open	Closed
7	Closed	Open

3. (a) Apply positive (+) source voltage to terminal 2.

NOTE: If bench testing, Step 3 can be used with either relay. When installed on engine, Step 3 can only be checked with TD2. **Do not apply positive (+) voltage to terminal 2 of TD1, or a direct short will result.**

Check the time from the moment voltage is applied to verify chart that follows (do not leave voltage on terminal 2 for more than 60 seconds):

Terminals	Delay Time to Function	
	0 to 8 Secs.	After 10 Secs.
5	Closed	Open
7	Open	Closed

- (b) Remove positive (+) source voltage from terminal 2. Check the time from the moment of removal to verify chart that follows:

Terminals	Delay Time to Function	
	0 to 60 Secs.	After 80 Secs.
5	Open	Closed
7	Closed	Open

4. Remove wire from terminal 4 and verify chart that follows:

Terminals	Relay Position
5	Closed
7	Open

# ELECTRIC SHUT-OFF WIRING DIAGRAMS

## COMPONENT ABBREVIATIONS (REF 5N360)

ALT	ALTERNATOR	OPS	OIL PRESSURE SWITCH
AMM	AMMETER	OPSS	OIL PRESSURE STEP SWITCH
ASOS	AIR SHUT-OFF SOLENOID	OPSU	OIL PRESSURE SENDING UNIT
ASSV	AIR START SOLENOID VALVE	OSI	OVERSPEED INDICATOR
B—	BATTERY NEGATIVE	OSS	OVERSPEED SWITCH
B+	BATTERY POSITIVE	PB	PUSH BUTTON
BATT	BATTERY	PP	PRELUBE PUMP
CB	CIRCUIT BREAKER	PPMS	PRELUBE PUMP MAGNETIC SWITCH
CT	CRANK TERMINATE	PPPS	PRELUBE PUMP PRESSURE SWITCH
D	DIODE	PS	PINION SOLENOID
EGA	ELECTRIC GOVERNOR ACTUATOR	RES	RESISTOR
EGC	ELECTRIC GOVERNOR CONTROL	RESS	REMOTE EMERGENCY SHUT-OFF SWITCH
ESS	ELECTRIC SPEED SWITCH	RNS	REMOTE NORMAL SHUT-OFF SWITCH
FSOS	FUEL SHUT-OFF SOLENOID	RSS	REMOTE START SWITCH
HWTAS	HIGH WATER TEMPERATURE ALARM SWITCH	SM	STARTER MOTOR
LOPAS	LOW OIL PRESSURE ALARM SWITCH	SMMS	STARTER MOTOR MAGNETIC SWITCH
LWTAS	LOW WATER TEMPERATURE ALARM SWITCH	SR	SLAVE (SHUTDOWN) RELAY
MGOPG	MARINE GEAR OIL PRESSURE GAGE	TD	TIME DELAY
MGOPSU	MARINE GEAR OIL PRESSURE SENDING UNIT	TM	TACHOMETER
MGOTAS	MARINE GEAR OIL TEMPERATURE ALARM SWITCH	TS	TERMINAL STRIP
MPU	MAGNETIC PICK-UP	WTG	WATER TEMPERATURE GAGE
NSS	NORMAL SHUT-OFF SWITCH	WTI	WATER TEMPERATURE INDICATOR
OPG	OIL PRESSURE GAGE	WTS	WATER TEMPERATURE SWITCH
OPI	OIL PRESSURE INDICATOR	WTSU	WATER TEMPERATURE SENDING UNIT
		Z	ZENER DIODE

## WIRE COLOR CODE ABBREVIATIONS

B	BLACK
BR	BROWN
B/W	BLACK WITH WHITE STRIPE
CU	COPPER (BARE WIRE)
DK BL	DARK BLUE
DK GR	DARK GREEN
GR	GREEN
LT BL	LIGHT BLUE
O	ORANGE
O/B	ORANGE WITH BLACK STRIPE
P/B	PINK WITH BLACK STRIPE
PU/W	PURPLE WITH WHITE STRIPE
R	RED
W	WHITE
W/O	WHITE WITH ORANGE STRIPE
W/R	WHITE WITH RED STRIPE
Y	YELLOW
Y/BR	YELLOW WITH BROWN STRIPE

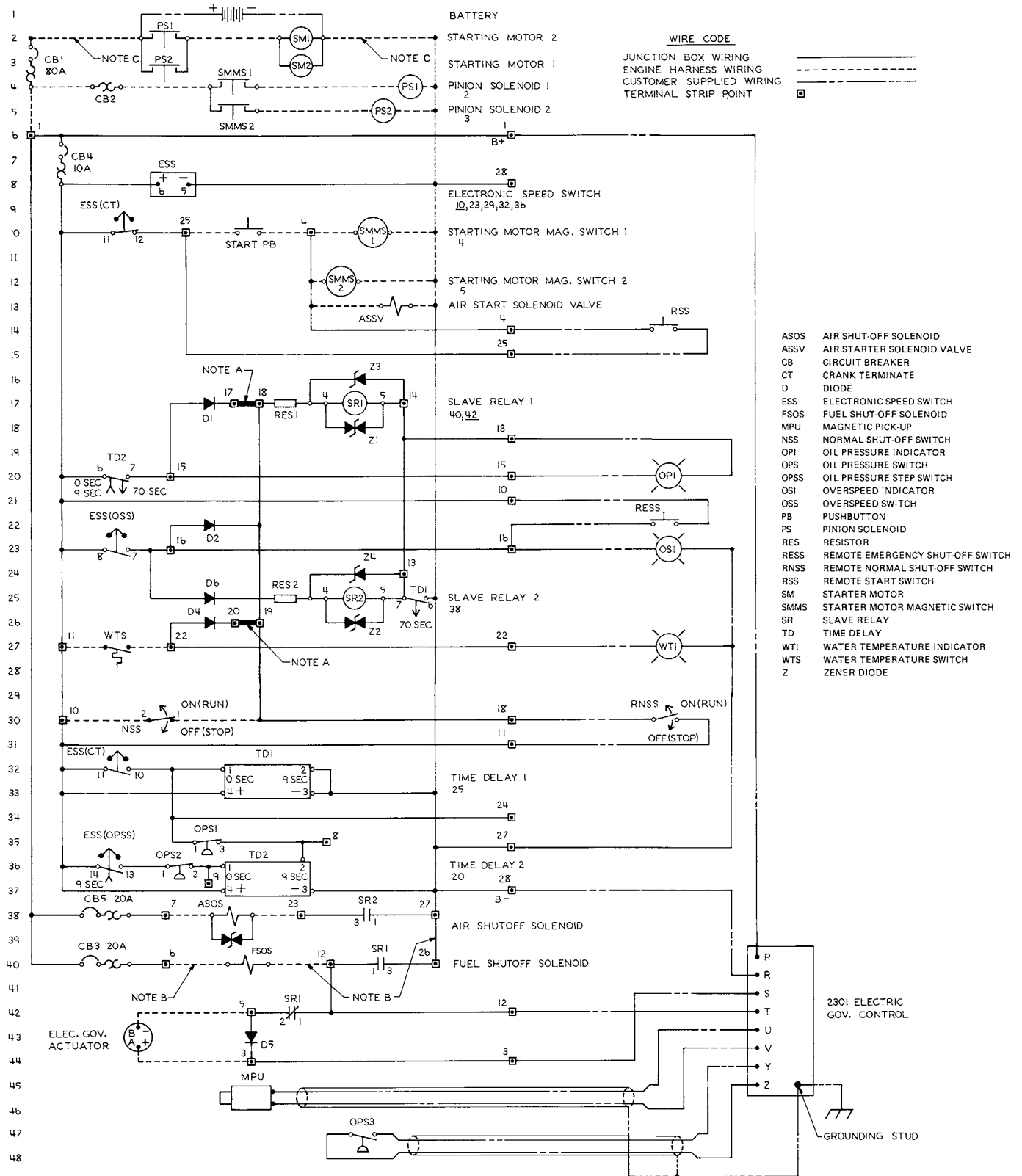

ELECTRIC PROTECTIVE SYSTEM SCHEMATIC

**NOTE A:** Terminal strip jumpers between terminals TS17 & TS18 and TS19 & TS20 are not required when alarms are used for low oil pressure and high water temperature.

**NOTE B:** The terminal strip wire between terminals TS26 & TS27 is in the wiring harness when a 3161, UG8D or UG8L governor is installed. When a 2301 governor is used, no wire is required; also, no fuel shutoff solenoid is used between TS6 & TS12.

**NOTE C:** This wire is provided by customer if electric starter motor(s) are not used.

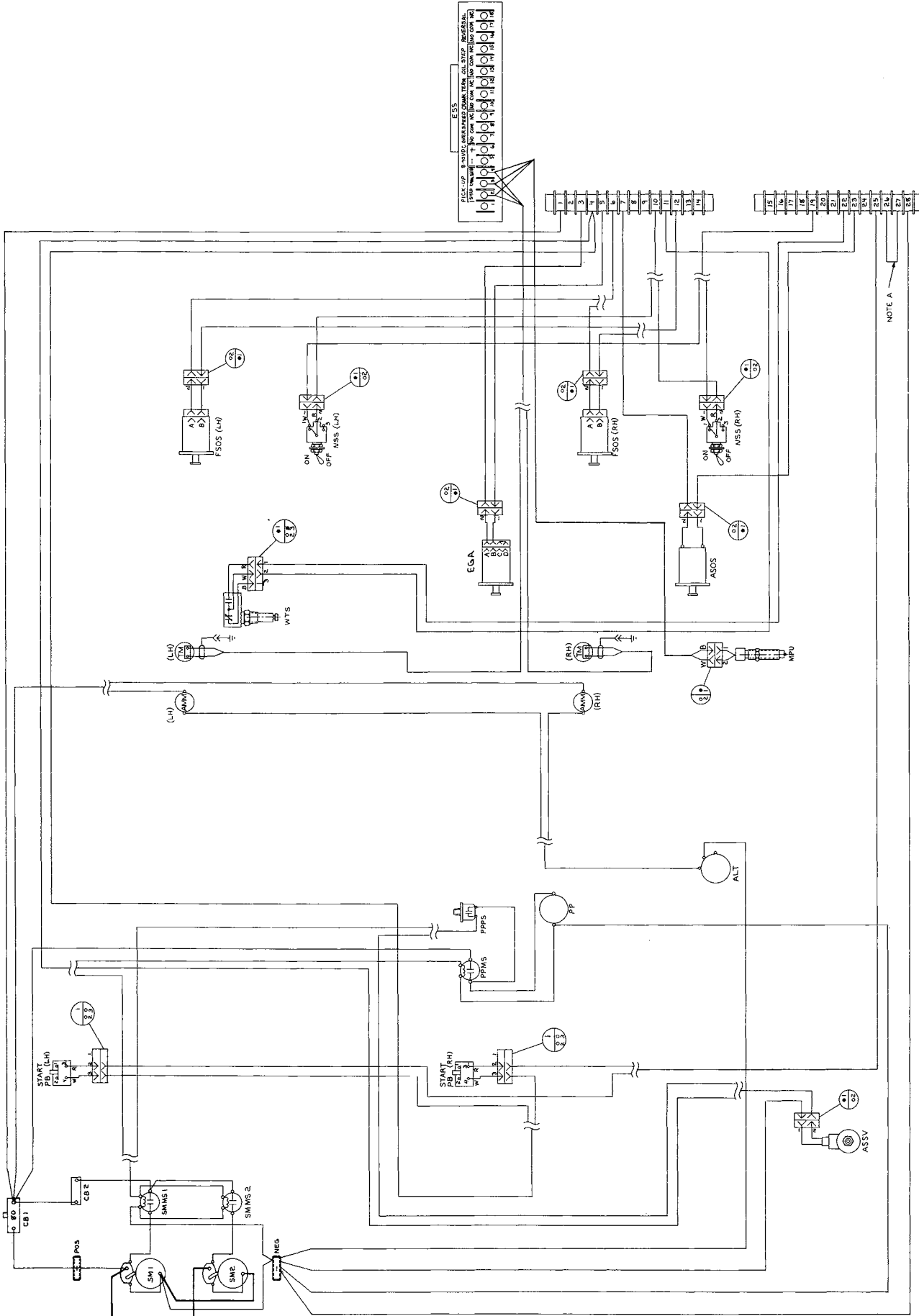

3500 ENGINE WIRING DIAGRAM (REF 5N8944)  
(All Possible Combinations)

NOTE A: Jumper required only with 3161, UG8D and UG8L governors.

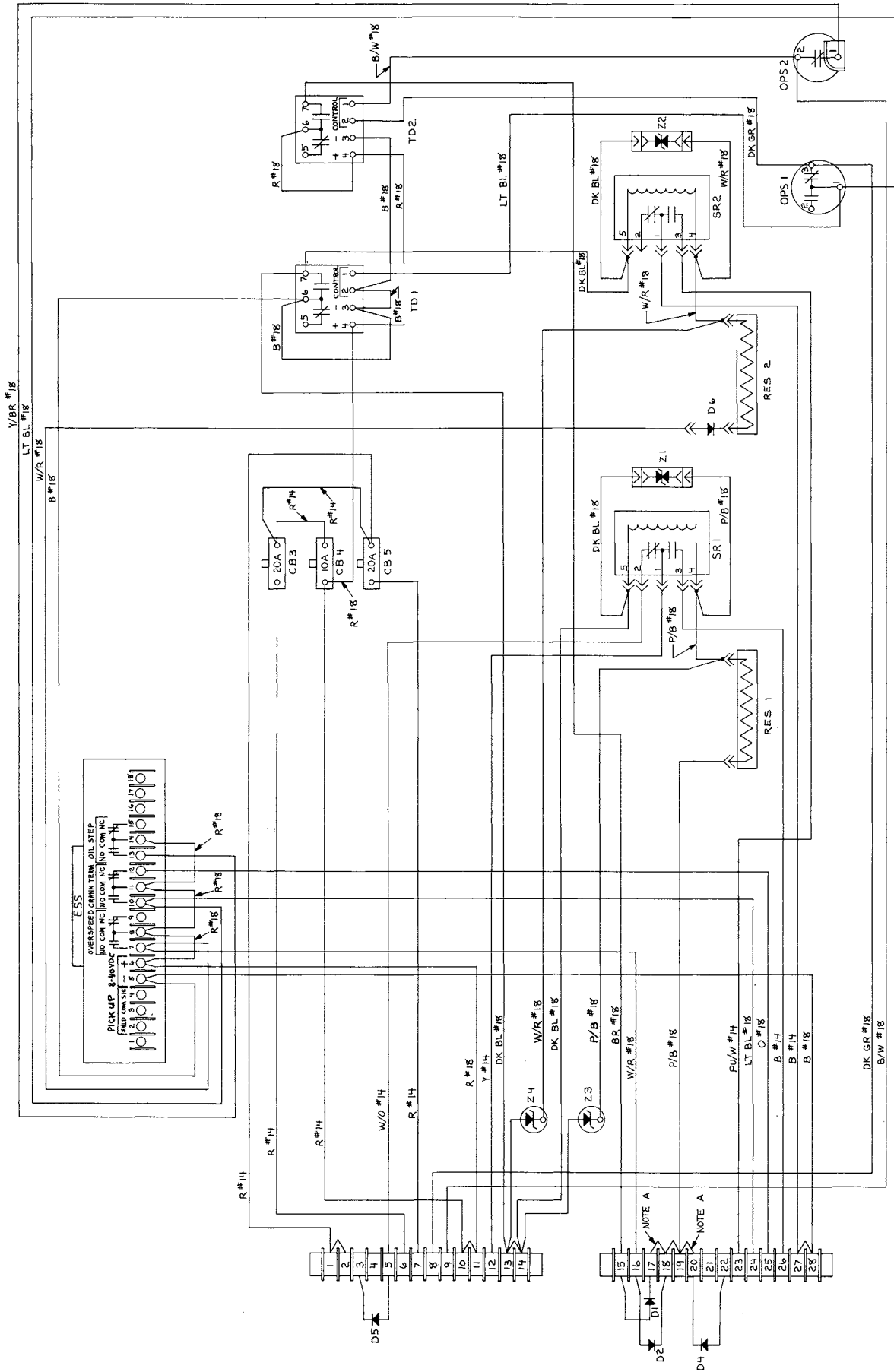

TYPICAL JUNCTION BOX WIRING DIAGRAM (REF 5N8944)

NOTE A: Terminal strip jumpers between terminals TS17 & TS18 and TS19 & TS20 are not required on Marine Engines which have alarms only for low oil pressure and high water temperature.





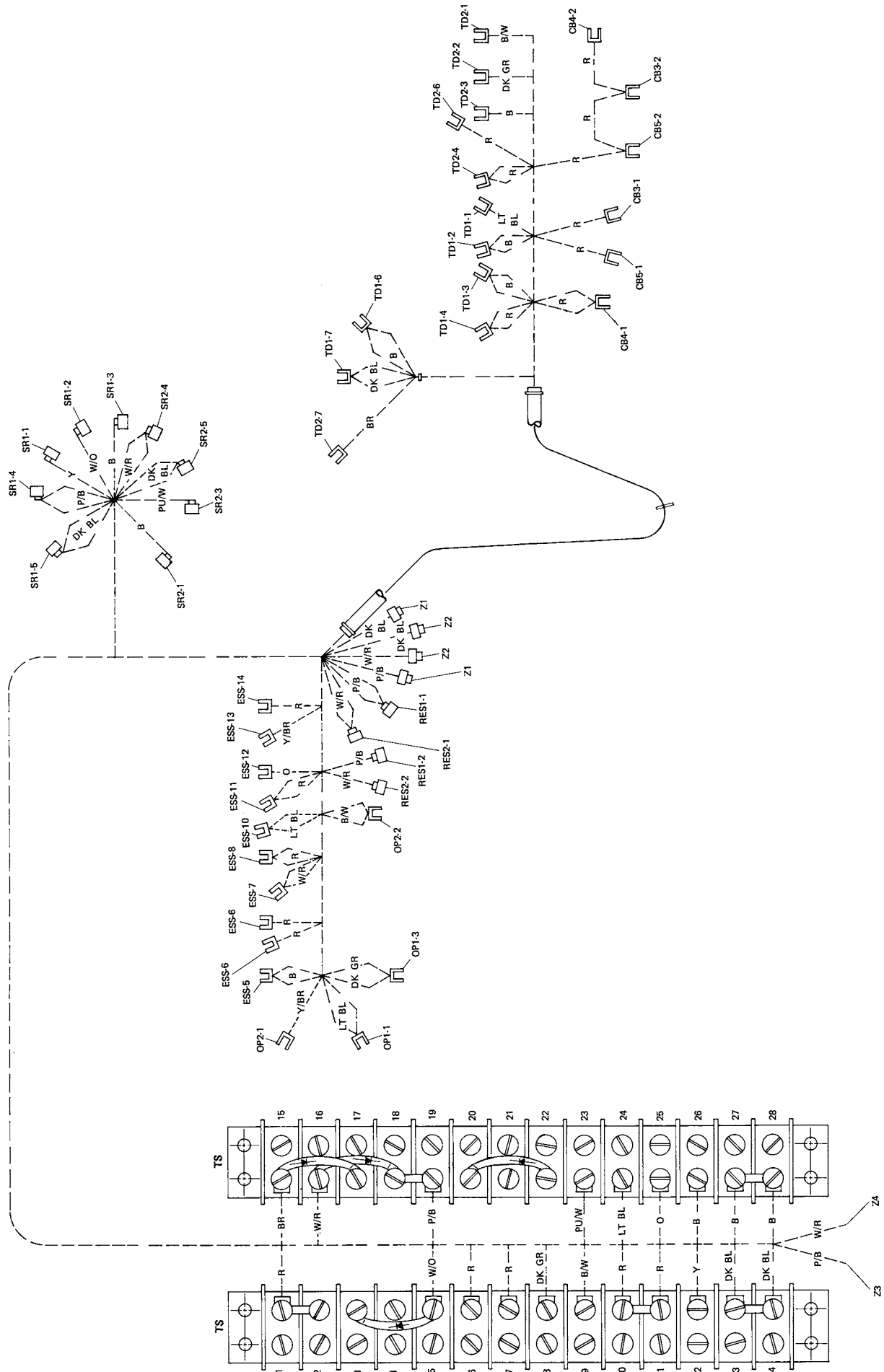

JUNCTION BOX WIRING HARNESS (REF 4W2636)

**ELECTRIC PROTECTIVE SYSTEM**

**WIRING DIAGRAMS**

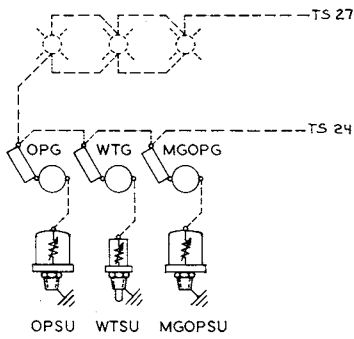
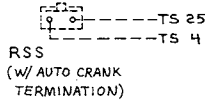
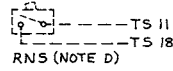
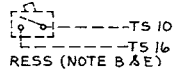
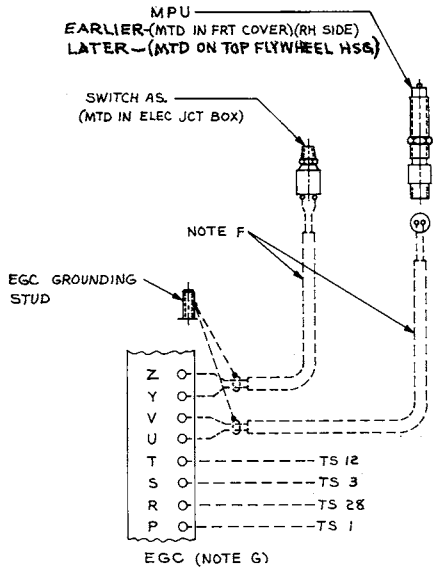

ELECTRIC GAGES WITH RESISTORS IN SERIES FOR USE WITH 32V SYSTEM

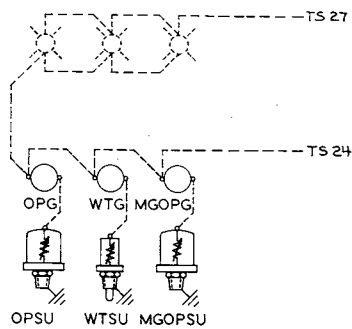

ELECTRIC GAGES FOR USE WITH 24V SYSTEM (RESISTORS NOT REQUIRED)

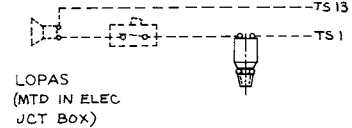
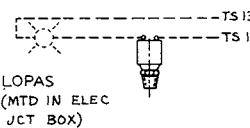
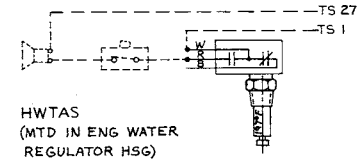
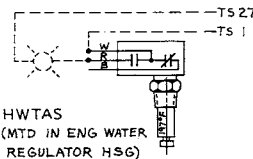
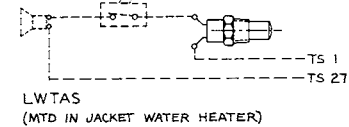
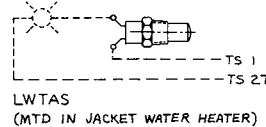
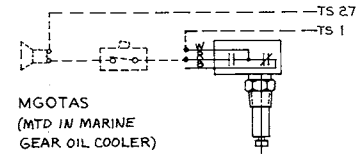
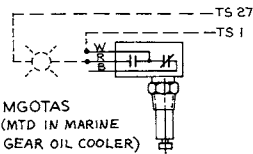
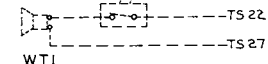
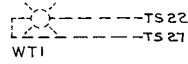
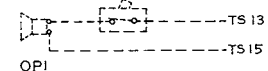
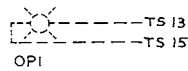
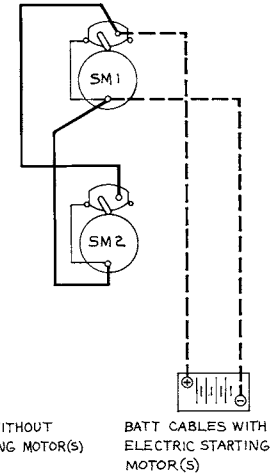
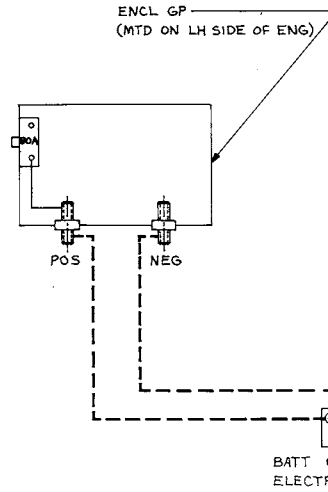

VISUAL ALARMS  
NOTE C

AUDIBLE ALARMS  
NOTE C

**CUSTOMER WIRING WITH ELECTRIC PROTECTIVE SYSTEM (NOTE A)**

**SEE NOTES ON PAGE THAT FOLLOWS**

NOTE A: Wire, cable and components shown with dotted lines are to be added by customer. See wire and cable gage charts for size selection.

NOTE B: Do not use remote emergency switch for normal engine shutdown. The use of emergency switch requires manual reset of air shut-off at top of air inlet housing.

NOTE C: Caterpillar alarm and prealarm contacts are rated for a maximum of 3 amps inductive at the charging system voltage.

NOTE D: Switch to be a single pole, normally open switch (may be latching if desired) with a minimum contact rating of .5 amp inductive at the charging system voltage.

NOTE E: Switch to be a single pole, normally open switch (may be latching if desired) with a minimum contact rating of 1 amp inductive at the charging system voltage.

NOTE F: Magnetic pick-up and oil pressure switch to be wired to electric governor control (Woodward 2301) with a two conductor shielded cable (Belden Corp. type 8780 or equivalent). Shields are to be grounded at electric governor control grounding stud. Each shield should not have more than one ground connection.

NOTE G: Woodward 2301 Electric Governor Control terminal identification chart:

SYMBOL	FUNCTION	STAND-BY TS NO.	LOAD SHARING TS NO.
P	Batt +	2	12
R	Batt —	1	13
S	EGA +	6	17
T	EGA —	5	16
U	Mag Pick-up	7	18
V	Mag Pick-up	8	19
Y	Oil Pressure Speed Limiter	9	14
Z	Oil Pressure Speed Limiter	10	15

**CATERPILLAR®**