

Emergency Stop Switches 444
 Operating Instructions..... 448

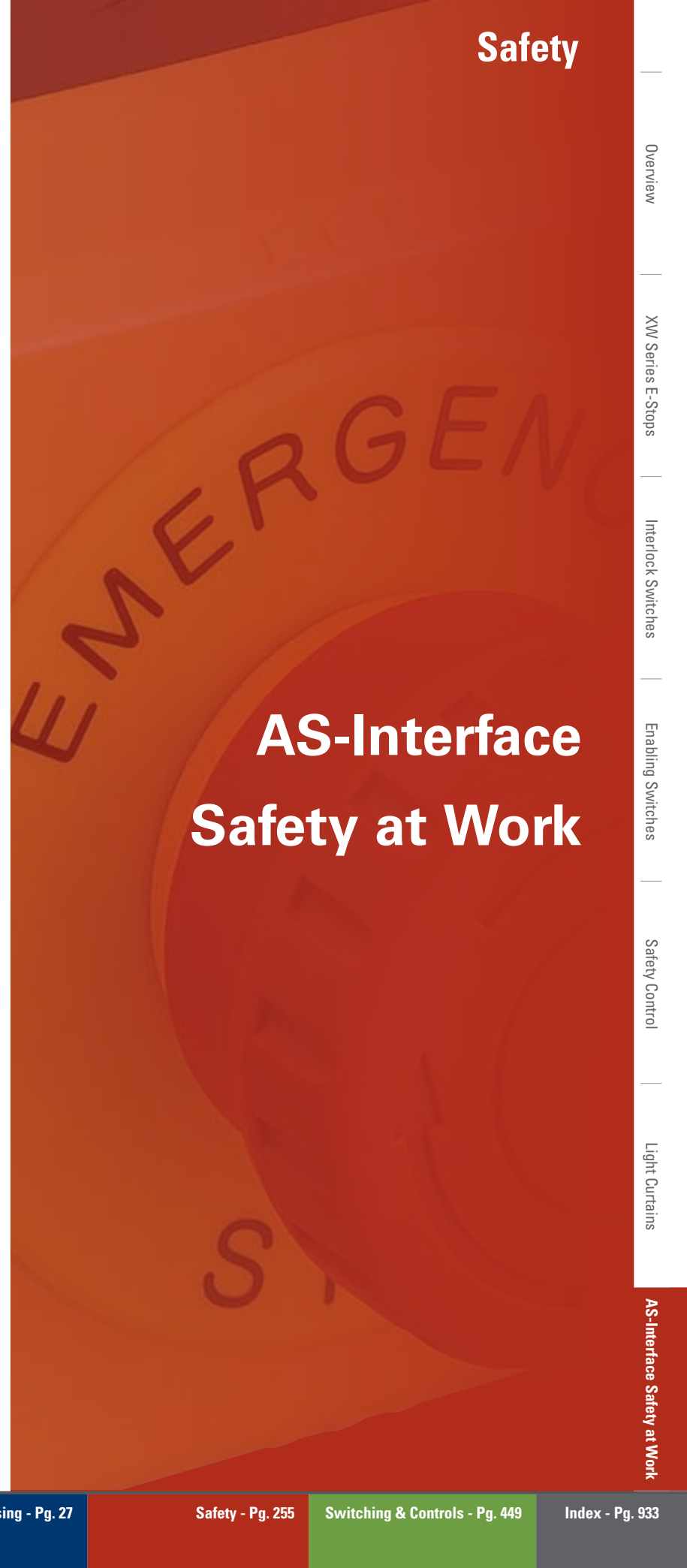

AS-Interface Safety at Work



www.IDEC.com/safety



Overview

XW Series E-Stops

Interlock Switches

Enabling Switches

Safety Control

Light Curtains

AS-Interface Safety at Work

AS-Interface Safety at Work

AS-Interface safety at work integrates a safety network into one wire-saving system.

- Safety slaves and safety monitors can be simply connected to the existing AS-Interface network to establish the AS-Interface Safety at Work.
- Emergency stop switches can be connected directly to AS-Interface Safety at Work, further reducing wiring.
- Interlock switches, safety relay modules and other safety components can be connected to the safety network via safety slaves.
- Safety components can be connected to other networks through gateways.

SX5A AS-Interface Safety Communication Terminal (Safety Slave)

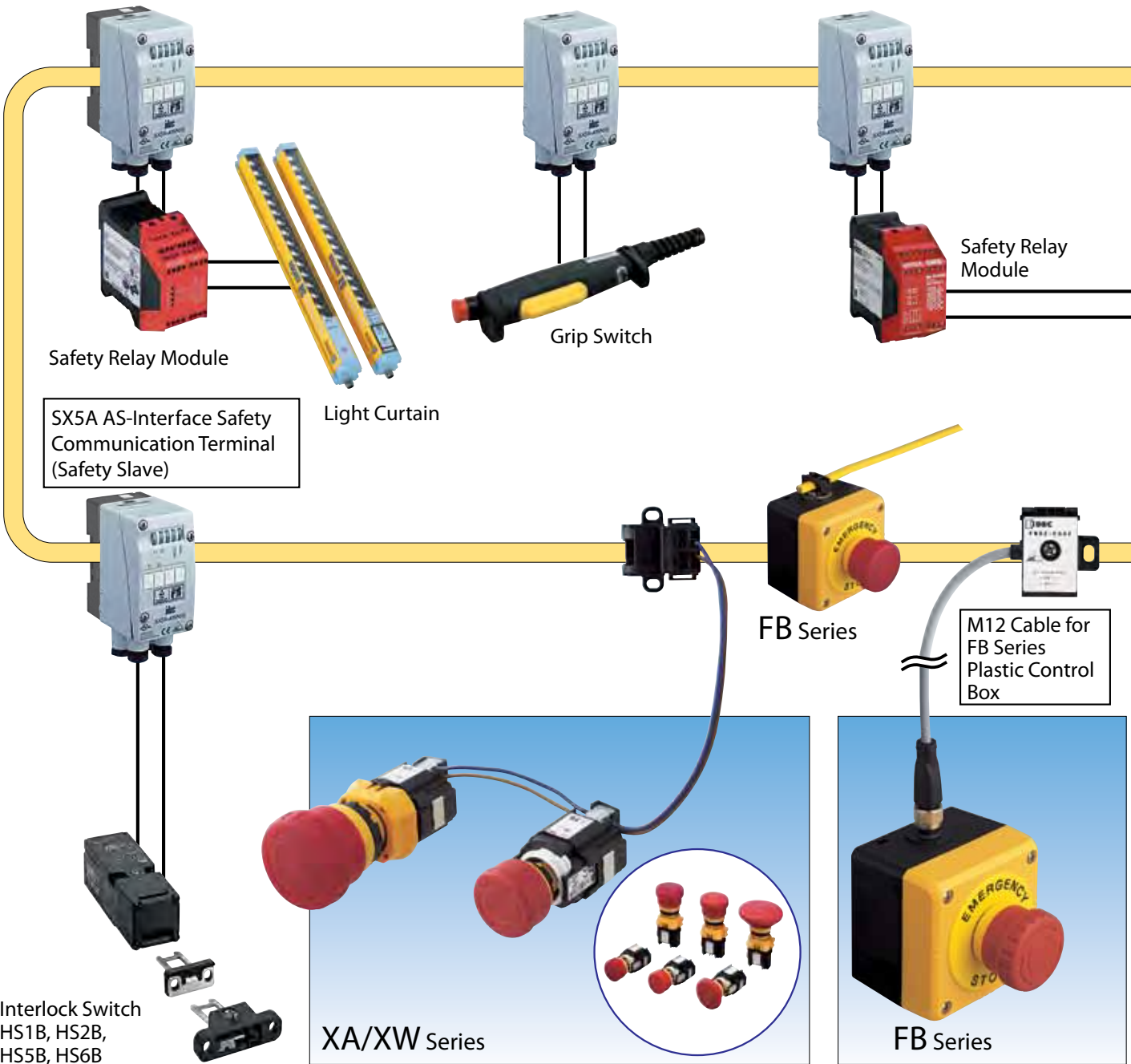

Overview

XW Series E-Stops

Interlock Switches

Enabling Switches

Safety Control

Light Curtains

AS-Interface Safety at Work

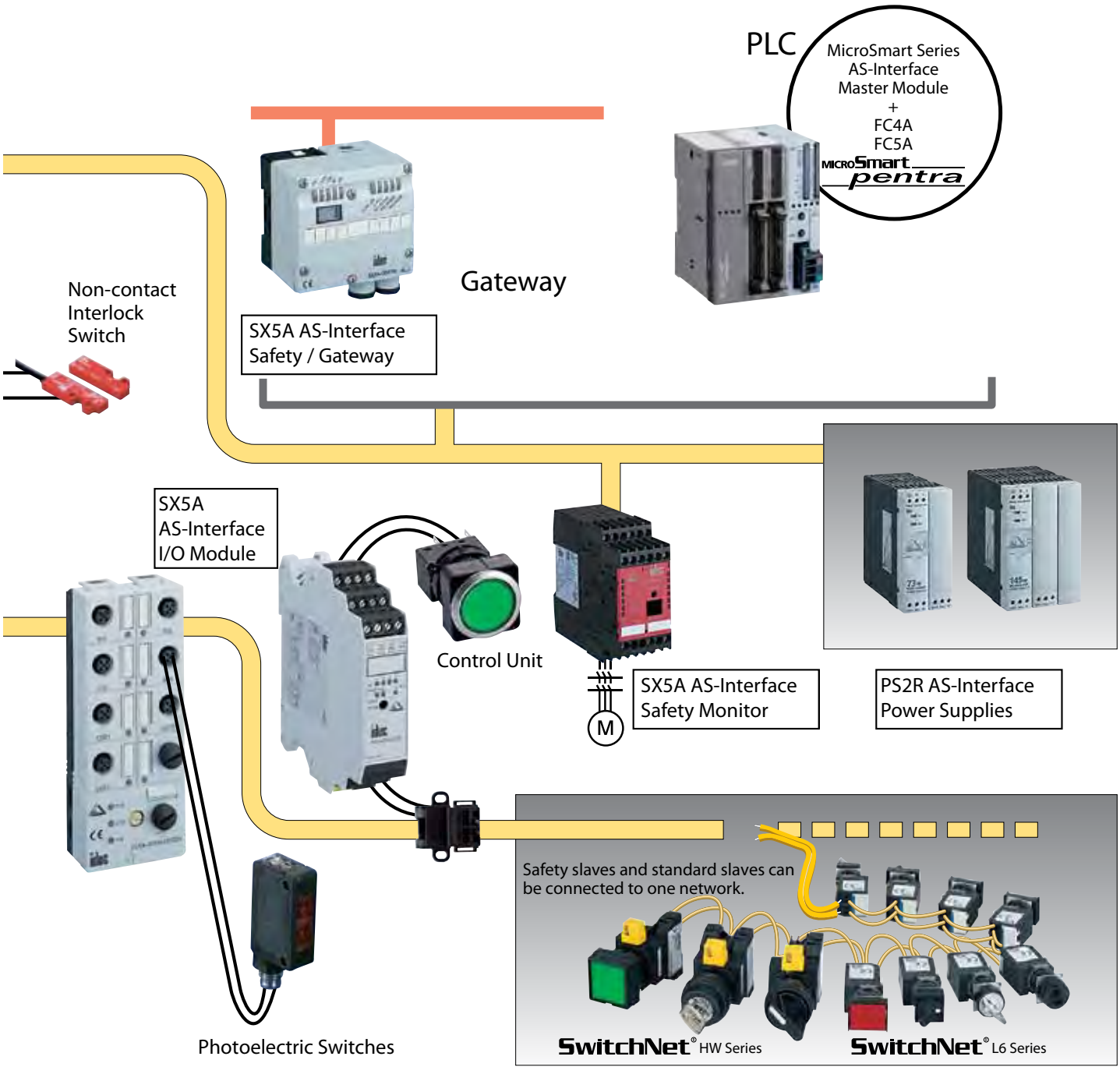

Emergency Stop Switches

XA Series/XW Series/FB Series (Plastic Enclosures) with Safety Slave Functions for Direct Connection to the AS-Interface Safety at Work

- Emergency stop switches with safety slave functions can be connected to the AS-Interface Safety at Work network.
- Complies with IEC 61508 SIL3 (Functional safety of electrical/electronic/programmable electronic safety-related systems) and EN954-1 safety category 4 (Safety of machinery-Safety related parts of control systems).
- Space, wire, and labor-saving solutions for safety equipment
- Equipped with AS-Interface standard slave functions. Monitored with AS-Interface master devices.
- A wide variety of safety components:
 - 1) 1-IN (non-illuminated) and 1-IN/1-OUT (illuminated) available.
 - 2) FB series plastic control stations with ø16mm XA series and ø22mm XW series emergency stop switches available.
 - 3) XA series available with ø29mm and ø40mm mushroom buttons and XW series available with ø40mm and ø60mm jumbo mushroom buttons.
 - 4) Terminal connectors are available in insulation displacement, crimping, and M12 connectors which enable effective connection of multiple switches.



Part Numbers

ø16mm XA Series

Button Size	Connector Terminal	I/O Points	Illumination	Part Number	Button/Lens Color
ø29	IDC	1-IN	Non-illuminated	XA1E-BV3Z10C1R	Red
				XA1E-BV3Z10C1N	Gray
1-IN 1-OUT		Illuminated	XA1E-LV3Z114C1R	Red	
ø40		1-IN	Non-illuminated		XA1E-BV4Z10C1R
	1-IN 1-OUT		Illuminated	XA1E-LV4Z114C1R	

ø22mm XW Series

Button Size	Connector Terminal	I/O Points	Illumination	Part Number	Button/Lens Color
ø40	IDC	1-IN	Non-illuminated	XW1E-BV4Z10C1R	Red
	Crimping			XW1E-BV4Z10C2R	
	IDC	1-IN 1-OUT	Illuminated	XW1E-LV4Z114C1R	
	Crimping			XW1E-LV4Z114C2R	
ø60	IDC	1-IN	Non-illuminated	XW1E-BV5Z10C1R	
	Crimping			XW1E-BV5Z10C2R	

E-Stop Enclosure

Button Size	Connector Terminal	I/O Points	Illumination	Nameplate	Part Number	Button/Lens Color
ø40	M12	1-IN	Non-illuminated	Without	FB1W-XW1E-BV4Z10C2R-Y0-1	Red
				With	FB1W-XW1E-BV4Z10C2R-Y1-1	
		1-IN 1-OUT	Illuminated	Without	FB1W-XW1E-LV4Z114C2R-Y0-1	
				With	FB1W-XW1E-LV4Z114C2R-Y1-1	
ø60		1-IN	Non-illuminated	Without	FB1W-XW1E-BV5Z10C2R-Y0-1	
				With	FB1W-XW1E-BV4Z10C2R-Y0-2	
ø40	AS- Interface Piercing	1-IN	Non-illuminated	Without	FB1W-XW1E-BV4Z10C2R-Y0-2	
				With	FB1W-XW1E-BV4Z10C2R-Y1-2	
		1-IN 1-OUT	Illuminated	Without	FB1W-XW1E-LV4Z114C2R-Y0-2	
				With	FB1W-XW1E-LV4Z114C2R-Y1-2	
ø60		1-IN	Non-illuminated	Without	FB1W-XW1E-BV5Z10C2R-Y0-2	

1. Units have been evaluated as emergency stop devices by TÜV.
 2. Units with nameplates are engraved "Emergency Stop".

Overview

XW Series E-Stops

Interlock Switches

Enabling Switches

Safety Control

Light Curtains

AS-Interface Safety at Work

Accessories

Name	Specification	Part Number
XA/XW Series IDC Connector Kit ¹	End connector (with cover)	XW9Z-C100-1
	Through connector (with cover)	XW9Z-C100-2
IDC Connector Termination Tool	Manufactured by ITW Pancon	MMIT-156F
Crimping Type Connector Cable	Length 500 mm, with one connector	XW9Z-C205
	Length 1m, with one connector	XW9Z-C210
FB Series Control Station M12 Connector Cable	Length 300 mm, straight	FB9Z-CS03
	Length 1m, straight	FB9Z-CS10
	Length 2m, straight	FB9Z-CS20
	Length 1m, right-angle	FB9Z-CL10
	Length 2m, right-angle	FB9Z-CL20
Hand-held Programming Device ²		SX9Z-ADR1N



- Minimum order is 5 pieces. IDC connector termination tool MMIT-156F (ITW Pancon) may be required to connect the cable to the connector.
- *Hand-held programming device accessories:
 - Programming device cable (SX9Z-CN1)
 - Programming device AC adapter (SX9Z-ADPT)
 - SwitchNet addressing port adapter (LA9Z-SNADP)

Specifications

		Operating Voltage	
General	Rated Input Current	26.5 to 31.6V DC (supplied from AS-Interface)	
	Dielectric Strength	Illuminated type: 35 mA (XA series), 40 mA (XW, FB series) Non-illuminated type: 25 mA	
	Insulation Resistance	500V AC, 1 minute	
	Operating Temperature	100 MΩ (500V DC megger)	
	Storage Temperature	XA, XW series: -25 to +55°C (no freezing) FB series: Illuminated type -25 to +50°C (no freezing) Non-illuminated type -25 to +55°C (no freezing)	
	Operating Humidity	-40 to +70°C (no freezing)	
	Pollution Degree (IEC60664)	45 to 85% RH (no condensation)	
	Degree of Protection	XA, XW series - Operator unit: 3, Communication unit: 2, FB series: 3 (2 - per UL)	
	IEC60529	Operator unit: IP65	
	Corrosion Immunity	Terminal unit: IP20 (FB series: IP65)	
	Vibration Resistance	Free from corrosive gases	
	Shock Resistance	Damage limits/Operating extremes: 10 to 500 Hz, amplitude 0.35 mm, acceleration 50 m/s ²	
	Weight (approx.)	Damage limits: 150 m/s ² , Operating extremes: 1000 m/s ²	
	Communication	Communication	XA series ø29: 35g, ø40: 40g XW series ø40: 60g, ø60: 70g FB series M12 connector: 195g (ø40), 205g (ø60) Piercing: 235g (ø40), 245g (ø60)
Slave Type		AS-Interface Ver. 3.0	
Maximum Network Length		Safety slave	
Maximum No. of Slaves		100m total	
Profile (I/O, ID, ID2)		31 (when only safety slaves are connected)	
Data Bit		Input	S-7, B, E (illuminated type) S-0, B, E (non-illuminated type)
		Output	Emergency stop switch DI0 DI1 DI2 DI3 When pressed 0 0 0 0 Emergency stop switch DI0 DI1 DI2 DI3 When not pressed X X X X x0.1 (unspecified)
Parameter Bit		D00 = 1 Pilot light: on D01 to 3: not used D00 = 0 Pilot light: off	
	Not used		

Overview

XW Series E-Stops

Mechanical/Electrical	Operating Force	Pushlock: 10.5N (XA series), 32N (XW, FB series) Pull reset: 10N (XA series), 21N (XW, FB series) Turn reset: 0.16N-m (XA series), 0.27 N-m (XW, FB series)
	Minimum Force Required for Direct Opening Action	60N (XA series), 80N (XW, FB series)
	Minimum Operator Stroke Required for Direct Opening Action	4.0 mm
	Maximum Operating Stroke	4.5 mm
	Operating Frequency	900 operations/hour
	Mechanical Life	250,000 operations minimum
	Electrical Life	250,000 operations minimum
	Connectors	IDC connector (XA series) IDC connector, crimping connector (XW series) M12 connector/AS-Interface piercing connector (FB series)
Recommended Tightening Torque for Locking Ring	0.88 N-m (XA series), 2.0 N-m (XW series)	

Interlock Switches

Enabling Switches

Safety Control

Light Curtains

Pin Assignment

XA/XW Series

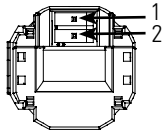
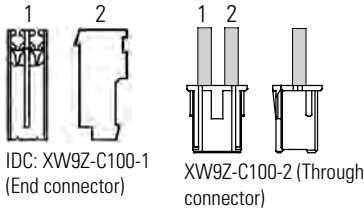

FB Series (M12 Connector)

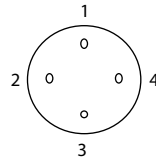

(AS-Interface Piercing Connector)

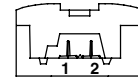

1: AS-+
2: AS-i-

Dimensions

XA Series

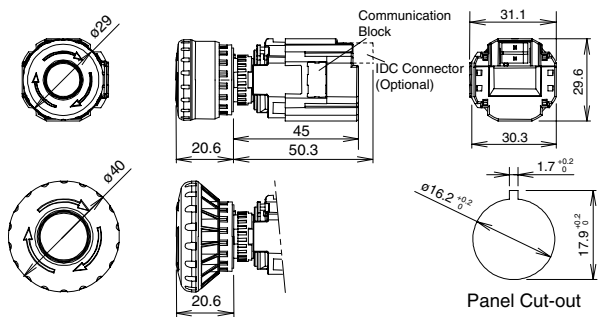

XW Series

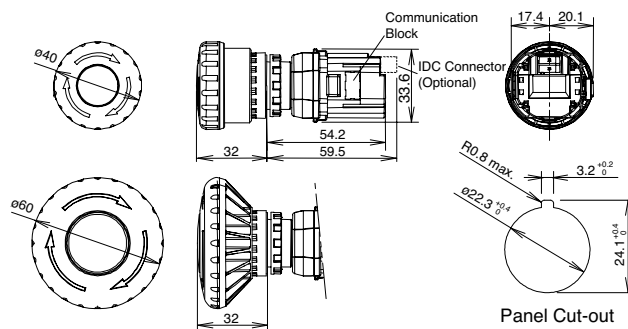

FB Series

AS-Interface Cable Piercing Model

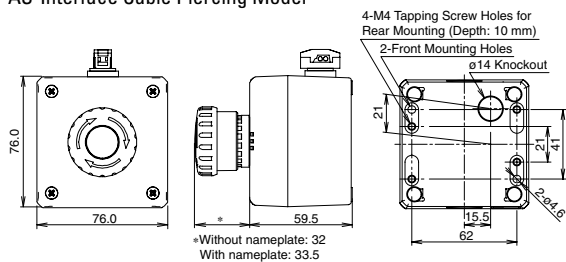

M12 Connector Cable for FB Series

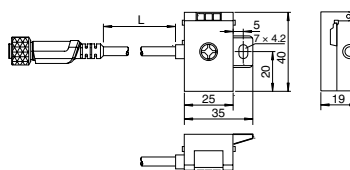

M12 Connector Model

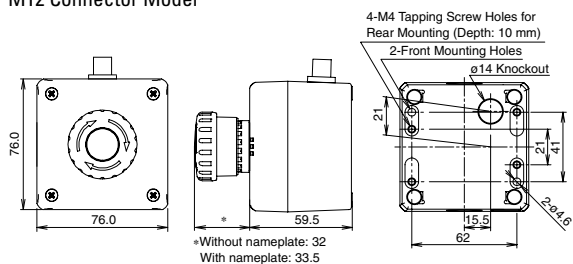

Mounting Centers

XA Series

XA Size	X & Y
ø29	40mm minimum
ø40	50mm minimum
ø60	70mm minimum

The above values are for installing with ø16mm pushbutton switches. For using with control units of other size and operator shape, determine the mounting centers in consideration of easy operation and wiring.

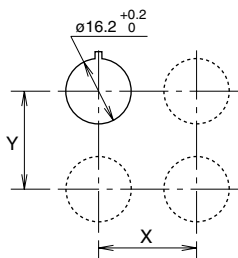

XW Series

XW Size	øA	X & Y
40mm	22.3 ^{+0.4}	70mm min

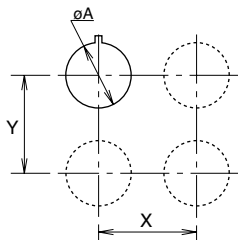

Resetting

These emergency stop switches are push-lock, pull/turn reset types. When pressed, the operator is latched, and reset by pulling or turning.

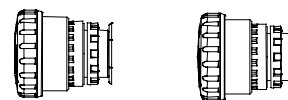

Overview

XW Series E-Stops

Interlock Switches

Enabling Switches

Safety Control

Light Curtains

AS-Interface Safety at Work

Operating Instructions

AS-Interface Safety Monitor

Wiring and Installation

Before wiring the interface cable, discharge static electricity. Tighten the screws to a torque of 0.8 to 1.2 N·m.

The AS-Interface power supply unit must separate the main power (input) and output safely according to IEC 60742. It must also maintain a stable supply in the event of instantaneous power failure.

Replacing the Safety Slave

Press "Service" button before and after replacing the safety slave. Resetting of safety monitor using the PC is not necessary. After replacement, check whether the new safety slave performs correctly.

Replacing the Safety Monitor

The settings of the safety monitor can be transferred to the new safety monitor using the download cable sold separately, and the new safety monitor does not require resetting using software. After replacement, check whether the new safety monitor performs correctly.

AS-Interface Safety Communication Terminal & Base Module

Wiring

The AS-Interface safety communication terminal will be connected to the AS-Interface network via the base module. When only one AS-i flat cable is used, plug the unused grooves using the gaskets supplied with the base module. Tighten the screws to a torque of 0.7 N·m maximum.

Before wiring, disconnect the safety communication terminal and discharge static electricity with an adequate method. Connect the emergency stop switches and interlock switches in normally-closed status.

The slave has two independent inputs for connecting the products to comply with the required safety category. When complying with safety category 4, limit the cable length between the module and the input device to not longer than 30m. For leading in the cables, use the upper part (1 and 2), and tighten the cable gland to a torque of 0.5 to 0.7 N·m.

Emergency Stop Switches

Panel Mounting

The panel thickness should be within the range from 0.8 to 6.0 mm. Remove the locking ring from the operator and check that the rubber gasket is in place. Insert the operator from panel front into the panel hole. Face the side without thread on the operator with TOP marking upward, and tighten the locking ring using ring wrench MW9Z-T1 to a torque of 2.0 N·m maximum. Do not use pliers. Do not tighten with excessive force, otherwise the locking ring will be damaged.

To prevent the XW emergency stop switches from rotating when resetting from the latched position, use of an anti-rotation ring (HW9Z-RL) or a nameplate is recommended.

Address Setting

The lid of the address setting device on the side of the unit can be removed by prying it out. Take care not to lose the lid, which comes off completely. By removing the lid of the address setting section, you can see the terminals for connecting a programming cable. Connect the programming cable to the terminals.

To set an address while mounting this product on the panel, more than 60mm space is necessary on the left side in terms of the AS-Interface communication unit. Note that adequate space cannot be allocated by the distance specified with minimum mounting centers. If adequate space cannot be allocated, set the address before installing the product on the panel or set the address after removing the AS-Interface communication unit from the operation section.

Wiring

A maximum of 31 units can be connected to a network. Addresses must be assigned to avoid overlaps.

This product allows connecting safety slaves with safety equipment, and normal slaves without safety equipment at the same time. Do not connect safety related signals to a normal slave.

The AS-Interface slaves are divided into two types: A/B slaves with expanded addresses and standard slaves without expanded addresses. If A/B slaves and standard slaves are connected simultaneously, the maximum number of slaves connectable to a network may exceed 31.

The network length is a maximum of 100 meters, including all wires. However, the maximum possible length of the wires may actually be shorter than 100 meters depending on the type of master and composition of slaves. Consider the lengths of cables and wiring topology so that voltage drops in transmission lines are no higher than 3V.

Use applicable two-wire flat cables for wiring.

Do not operate the switch using solid object such as metal or with excessive force, otherwise the switch may be deformed or damaged, causing malfunction or operation failure.